



LECTURE NOTES

ON

Applied Hydraulic Engineering (18CV43)

B.E IV semester

Mrs. Kavya B M. B.E M.Tech (Ph. D)

Assistant Professor,

Dept. of Civil Engineering

ADICHUNCHANAGIRI UNIVERSITY

**B G Nagara - 571448, NH-75, Nagamangala Taluk, Mandya District,
Karnataka, India.**

|| Jai Sri Gurudev||
Sri Adichunchanagiri Shikshana Trust (R)
ADICHUNCHANAGIRI UNIVERSITY
BGS Institute of Technology
B. E. CIVIL ENGINEERING
Choice Based Credit System (CBCS) and Outcome Based Education (OBE)

18CV43	Course Code	THEORY	Course Title	IV	Semester
	Credits	0 – 0 – 0 – 0	L – T – P – TL*	50 Hours	Teaching Period
100 Marks	Total	60 Marks	SEE*	40 Marks	CIE*
*NOTE: L – Lecture; T – Tutorial; P – Practical; TL – Total; CIE – Continuous Internal Evaluation; SEE – Semester End Examination					

<p>Course Learning Objectives: The objectives of this course is to make students to learn:</p> <ol style="list-style-type: none"> 1. Principles of dimensional analysis to design hydraulic models and Design of various models. 2. Design the open channels of various cross sections including design of economical sections. 3. Energy concepts of fluid in open channel, Energy dissipation, Water surface profiles at different conditions. 4. The working principles of the hydraulic machines for the given data and analyzing the performance of Turbines for various design data. 	Teaching Hours
<p>Module-1 Dimensional and Model analysis: Dimensional analysis Dimensional analysis and similitude: Dimensional homogeneity, Non Dimensional parameter, Rayleigh methods and Buckingham π theorem, dimensional analysis, choice of variables, examples on various applications. Model analysis: Model analysis, similitude, types of similarities, force ratios, similarity laws, model classification, Reynolds model, Froude's model, Euler's Model, Webber's model, Mach model, scale effects, Distorted models. Numerical problems on Reynold's, and Froude's Model. Buoyancy and Flotation Buoyancy, Force and Centre of Buoyancy, Metacentre and Metacentric height, Stability of submerged and floating bodies.</p>	10Hours
<p>Module-2 Open Channel Flow Hydraulics Uniform Flow Introduction, Classification of flow through channels, Chezy's and Manning's equation for flow through open channel, Most economical channel sections, Uniform flow through Open channels, Numerical Problems. Specific Energy and Specific energy curve, Critical flow and corresponding critical parameters, Metering flumes, Numerical Problems</p>	10Hours
<p>Module-3 Non-Uniform Flow Hydraulic Jump, Expressions for conjugate depths and Energy loss, Numerical Problems Gradually varied flow, Equation, Back water curve and afflux, Description of water curves or profiles, Mild, steep, critical, horizontal and adverse slope profiles, Numerical problems, Control section.</p>	10Hours

<p>Module-4 Hydraulic Machines Introduction, Impulse-Momentum equation. Direct impact of a jet on a stationary and moving curved vanes, Introduction to concept of velocity triangles, impact of jet on a series of curved vanes- Problems Turbines – Impulse Turbines Introduction to turbines, General lay out of a hydro-electric plant, Heads and Efficiencies, classification of turbines. Pelton wheel-components, working principle and velocity triangles. Maximum power, efficiency, working proportions – Numerical problems</p>	10Hours
<p>Module-5 Module 5: Reaction Turbines and Pumps <i>Radial flow reaction turbines:</i> (i) Francis turbine- Descriptions, working proportions and design, Numerical problems. (ii) Kaplan turbine- Descriptions, working proportions and design, Numerical problems. Draft tube theory and unit quantities. (No problems) <i>Centrifugal pumps:</i> Components and Working of centrifugal pumps, Types of centrifugal pumps, Work done by the impeller, Heads and Efficiencies, Minimum starting speed of centrifugal pump, Numerical problems, Multi-stage pumps.</p>	10Hours
<p>Course outcomes: After a successful completion of the course, the student will be able to:</p> <ol style="list-style-type: none"> 1. Apply dimensional analysis to develop mathematical modelling and compute the parametric values in prototype by analyzing the corresponding model parameters 2. Design the open channels of various cross sections including economical channel sections 3. Apply Energy concepts to flow in open channel sections, Calculate Energy dissipation, Compute water surface profiles at different conditions 4. Design turbines for the given data, and to know their operation characteristics under different operating conditions 	
<p>Question paper pattern: Total number of Questions to be set is 10. Two full questions are to be set from each module.</p> <ul style="list-style-type: none"> · Not more than 3 sub questions are to be set under any main question · Questions are to be set such that the entire module is covered and further, should be answerable for the set marks. · Each question should be set for 16 marks · Students should answer 5 full questions selecting at least 1 from each module. 	
<p>Textbooks: Text Books:</p> <ol style="list-style-type: none"> 1. P N Modi and S M Seth, “Hydraulics and Fluid Mechanics, including Hydraulic Machines”, 20th edition, 2015, Standard Book House, New Delhi 2. R.K. Bansal, “A Text book of Fluid Mechanics and Hydraulic Machines”, Laxmi Publications, New Delhi 3. S K SOM and G Biswas, “Introduction to Fluid Mechanics and Fluid Machines”, Tata McGraw Hill, New Delhi <p>Reference Books:</p> <ol style="list-style-type: none"> 1. K Subramanya, “Fluid Mechanics and Hydraulic Machines”, Tata McGraw Hill Publishing Co. Ltd. 2. Mohd. Kaleem Khan, “Fluid Mechanics and Machinery”, Oxford University Press 3. C.S.P. Ojha, R. Berndtsson, and P.N. Chandramouli, “Fluid Mechanics and Machinery”, Oxford University Publication – 2010 4. J.B. Evett, and C. Liu, “Fluid Mechanics and Hydraulics”, McGraw-Hill Book Company. -2009 	

Unit 1 UNIFORM FLOW

Prerequisite

The flow of water in a conduit may be either open channel flow or pipe flow. The two kinds of flow are similar in many ways but differ in one important respect.

Introduction

Open-channel flow must have a free surface, whereas pipe flow has none. A free surface is subject to atmospheric pressure. In Pipe flow there exists no direct atmospheric flow but hydraulic pressure only.

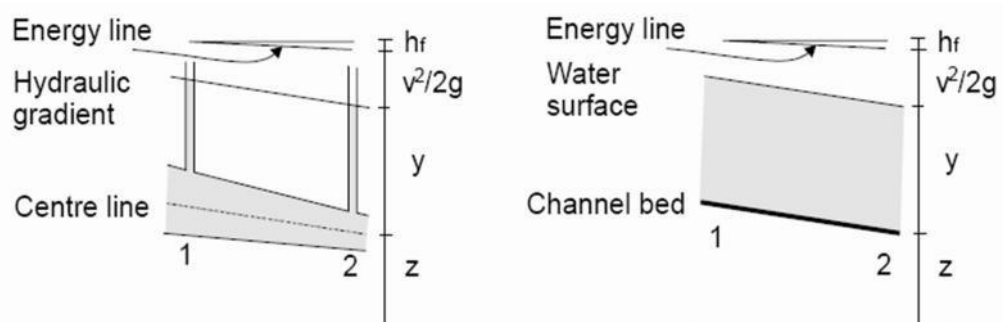

Figure of pipe and open channel flow

The two kinds of flow are compared in the figure above. On the left is pipe flow. Two piezometers are placed in the pipe at sections 1 and 2. The water levels in the pipes are maintained by the pressure in the pipe at elevations represented by the hydraulics grade line or hydraulic gradient .

The pressure exerted by the water in each section of the pipe is shown in the tube by the height y of a column of water above the centre line of the pipe.

The total energy of the flow of the section (with reference to a datum) is the sum of the elevation z of the pipe centre line, the piezometric head y and the velocity head $V^2/2g$, where V is the mean velocity. The energy is represented in the figure by what is known as the energy grade line or the energy gradient.

The loss of energy that results when water flows from section 1 to section 2 is represented by h_f .

A similar diagram for open channel flow is shown to the right. This is simplified by assuming parallel flow with a uniform velocity distribution and that the slope of the channel is small. In this case the hydraulic gradient is the water surface as the depth of water corresponds to the piezometric height.

Despite the similarity between the two kinds of flow, it is much more difficult to solve problems of flow in open channels than in pipes. Flow conditions in open channels are complicated by the position of the free surface which will change with time and space. And also by the fact that depth of flow, the discharge, and the slopes of the channel bottom and of the free surface are all inter dependent.

Physical conditions in open-channels vary much more than in pipes – the cross-section of pipes is usually round – but for open channel it can be any shape.

Treatment of roughness also poses a greater problem in open channels than in pipes. Although there may be a great range of roughness in a pipe from polished metal to highly corroded iron, open channels may be of polished metal to natural channels with long grass and roughness that may also depend on depth of flow.

Open channel flows are found in large and small scale. For example the flow depth can vary between a few cm in water treatment plants and over 10m in large rivers. The mean velocity of flow may range from less than 0.01 m/s in tranquil waters to above 50 m/s in high-head spillways. The range of total discharges may extend from 0.001 l/s in chemical plants to greater than 10000 m³ /s in large rivers or spillways.

In each case the flow situation is characterised by the fact that there is a free surface whose position is NOT known beforehand – it is determined by applying momentum and continuity principles.

Open channel flow is driven by gravity rather than by pressure work as in pipes.

Differences between Pipe Flow and Open Channel Flow

	Pipe flow	Open Channel flow
Flow driven by	Pressure work	Gravity (potential energy)
Flow cross section	Known, fixed	Unknown in advance because the flow depth is unknown
Characteristics flow parameters	velocity deduced from continuity	Flow depth deduced simultaneously from solving both continuity and momentum equations
Specific boundary conditions		Atmospheric pressure at the free surface

Types of flow

The following classifications are made according to change in flow depth with respect to time and space.

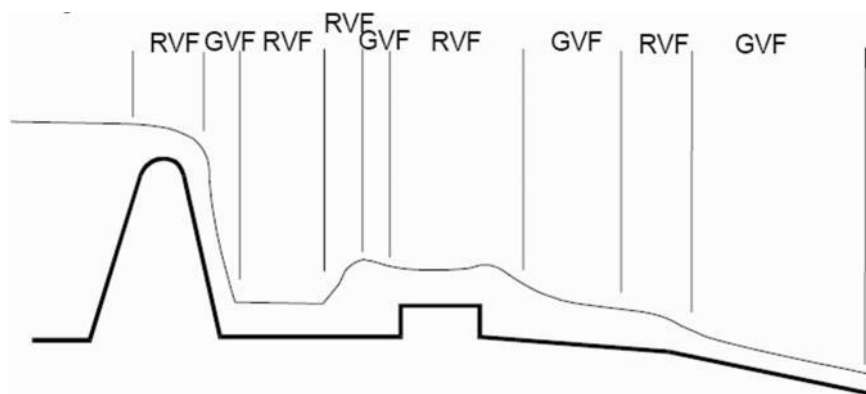

Figure of the types of flow that may occur in open channels

Steady and Unsteady: Time is the criterion.

Flow is said to be steady if the depth of flow at a particular point does not change or can be considered constant for the time interval under consideration. The flow is unsteady if depth changes with time.

Uniform Flow: Space as the criterion.

Open Channel flow is said to be uniform if the depth and velocity of flow are the same at every section of the channel. Hence it follows that uniform flow can only occur in prismatic channels.

For steady uniform flow, depth and velocity is constant with both time and distance. This constitutes the fundamental type of flow in an open channel. It occurs when gravity forces are in equilibrium with resistance forces.

Steady non-uniform flow.

Depth varies with distance but not with time. This type of flow may be either (a) gradually varied or (b) rapidly varied. Type (a) requires the application of the energy and frictional resistance equations while type (b) requires the energy and momentum equations.

Unsteady flow

The depth varies with both time and space. This is the most common type of flow and requires the solution of the energy momentum and friction equations with time. In many practical cases the flow is sufficiently close to steady flow therefore it can be analysed as gradually varied steady flow.

Properties of open channels

Artificial channels

These are channels made by man. They include irrigation canals, navigation canals, spillways, sewers, culverts and drainage ditches. They are usually constructed in a regular cross-section shape throughout – and are thus prismatic channels (they don't widen or get narrower along the channel).

In the field they are commonly constructed of concrete, steel or earth and have the surface roughness' reasonably well defined (although this may change with age – particularly grass lined channels.) Analysis of flow in such well defined channels will give reasonably accurate results.

Natural channels

Natural channels can be very different. They are not regular nor prismatic and their materials of construction can vary widely (although they are mainly of earth this can possess many different properties.) The surface roughness will often change with time distance and even elevation.

Consequently it becomes more difficult to accurately analyse and obtain satisfactory results for natural channels than it does for man made ones. The situation may be further complicated if the boundary is not fixed i.e. erosion and deposition of sediments.

Geometric properties necessary for analysis

For analysis various geometric properties of the channel cross-sections are required. For artificial channels these can usually be defined using simple algebraic equations given y the depth of flow. The commonly needed geometric properties are shown in the figure below and defined as:

Depth(y)—the vertical distance from the lowest point of the channel section to the free surface.

Stage (z) – the vertical distance from the free surface to an arbitrary datum

Area (A) – the cross-sectional area of flow, normal to the direction of flow

Wetted perimeter (P) – the length of the wetted surface measured normal to the direction of flow.

Surface width (B) – width of the channel section at the free surface

Hydraulic radius (R) – the ratio of area to wetted perimeter (A/P)

Hydraulic mean depth (D_m) – the ratio of area to surface width (A/B)

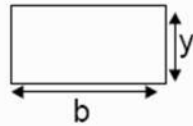
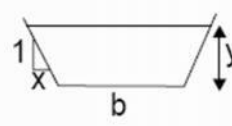
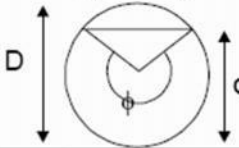
	Rectangle	Trapezoid	Circle
			
Area, A	by	$(b+xy)y$	$\frac{1}{8}(\phi - \sin \phi)D^2$
Wetted perimeter P	$b + 2y$	$b + 2y\sqrt{1+x^2}$	$\frac{1}{2}\phi D$
Top width B	b	$b+2xy$	$(\sin \phi/2)D$
Hydraulic radius R	$by/(b + 2y)$	$\frac{(b + xy)y}{b + 2y\sqrt{1+x^2}}$	$\frac{1}{4}\left(1 - \frac{\sin \phi}{\phi}\right)D$
Hydraulic mean depth D_m	y	$\frac{(b + xy)y}{b + 2xy}$	$\frac{1}{8}\left(\frac{\phi - \sin \phi}{\sin(1/2\phi)}\right)D$

Fundamental equations

The equations which describe the flow of fluid are derived from three fundamental laws of physics:

1. Conservation of matter (or mass)
2. Conservation of energy
3. Conservation of momentum

Although first developed for solid bodies they are equally applicable to fluids. Brief descriptions of the concepts are given below.

Conservation of matter

This says that matter can not be created nor destroyed, but it may be converted (e.g. by a chemical process.) In fluid mechanics we do not consider chemical activity so the law reduces to one of conservation of mass.

Conservation of energy

This says that energy can not be created nor destroyed, but may be converted form one type to another (e.g. potential may be converted to kinetic energy). When engineers talk about energy "losses" they are referring to energy converted from mechanical (potential or kinetic) to some other form such as heat. A friction loss, for example, is a conversion of mechanical energy to heat. The basic equations can be obtained from the First Law of Thermodynamics but a simplified derivation will be given below.

Conservation of momentum

The law of conservation of momentum says that a moving body cannot gain or lose momentum unless acted upon by an external force. This is a statement of Newton's Second **Law of Motion**: Force = rate of change of momentum

In solid mechanics these laws may be applied to an object which is has a fixed shape and is clearly defined. In fluid mechanics the object is not clearly defined and as it may change shape constantly. To get over this we use the idea of control volumes. These are imaginary volumes of fluid within the body of the fluid. To derive the basic equation the above conservation laws are applied by considering the forces applied to the edges of a control volume within the fluid.

The Continuity Equation (conservation of mass)

For any control volume during the small time interval δt the principle of conservation of mass implies that the mass of flow entering the control volume minus the mass of flow leaving the control volume equals the change of mass within the control volume. If the flow is steady and the fluid incompressible the mass entering is equal to the mass leaving, so there is no change of mass within the control volume.

So for the time interval δt : Mass flow entering = mass flow leaving

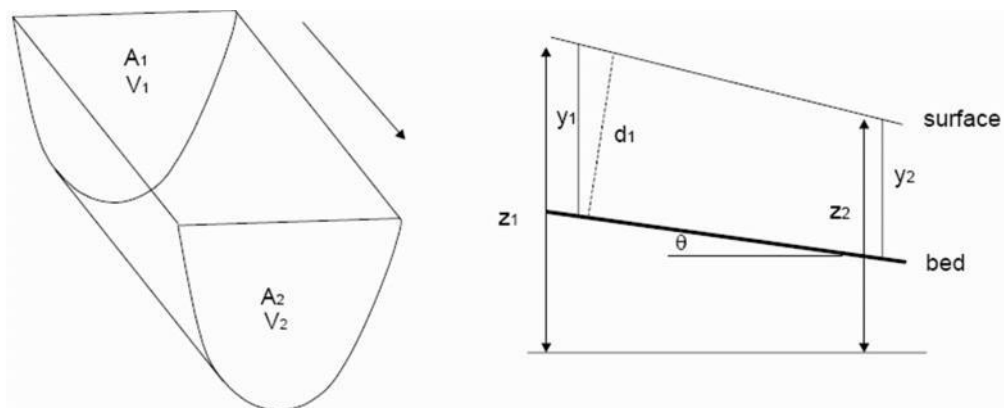

Figure of a small length of channel as a control volume

Considering the control volume above which is a short length of open channel of arbitrary cross- Section then, if ρ is the fluid density and Q is the volume flow rate then section then, if mass flow rate is ρQ and the continuity equation for steady incompressible flow can be written

$$\rho Q_{\text{entering}} = \rho Q_{\text{leaving}}$$

As, Q , the volume flow rate is the product of the area and the mean velocity then at the upstream face (face 1) where the mean velocity is u and the cross-sectional area is A_1 then:

$$Q_{\text{entering}} = u_1 A_1$$

Similarly at the downstream face, face 2, where mean velocity is u_2 and the cross-sectional area is A_2 then:

$$Q_{\text{leaving}} = u_2 A_2$$

Therefore the continuity equation can be written as

$$u_1 A_1 = u_2 A_2$$

The Energy equation (conservation of energy):

Consider the forms of energy available for the above control volume. If the fluid moves from the upstream face 1, to the downstream face 2 in time dt over the length L .

The work done in moving the fluid through face 1 during this time is

Where p_1 is pressure at face 1 $\text{work done} = p_1 A_1 L$

The mass entering through face 1 is

$$\text{mass entering} = \rho_1 A_1 L$$

Therefore the kinetic energy of the system is:

$$KE = \frac{1}{2} m u^2 = \frac{1}{2} \rho_1 A_1 L u_1^2$$

If z_1 is the height of the centroid of face 1, then the potential energy of the fluid entering the control volume is :

$$PE = mgz = \rho_1 A_1 L g z_1$$

The total energy entering the control volume is the sum of the work done, the potential and the kinetic energy:

$$\text{Total energy} = p_1 A_1 L + \frac{1}{2} \rho_1 A_1 L u_1^2 + \rho_1 A_1 L g z_1$$

We can write this in terms of energy per unit weight. As the weight of water entering the control volume is $\rho_1 A_1 L g$ then just divide by this to get the total energy per unit weight:

$$\text{Total energy per unit weight} = \frac{p_1}{\rho_1 g} + \frac{u_1^2}{2g} + z_1$$

At the exit to the control volume, face 2, similar considerations deduce

$$\text{Total energy per unit weight} = \frac{p_2}{\rho_2 g} + \frac{u_2^2}{2g} + z_2$$

If no energy is supplied to the control volume from between the inlet and the outlet then energy leaving = energy entering and if the fluid is incompressible

$$\frac{p_1}{\rho g} + \frac{u_1^2}{2g} + z_1 = \frac{p_2}{\rho g} + \frac{u_2^2}{2g} + z_2 = H = \text{constant}$$

This is the Bernoulli equation.

Note:

1. In the derivation of the Bernoulli equation it was assumed that no energy is lost in the control volume - i.e. the fluid is frictionless. To apply to non frictionless situations some energy loss term must be included.
2. The dimensions of each term in equation 1.2 has the dimensions of length (units of meters). For this reason each term is often regarded as a "head" and given the names

$$\begin{aligned} \frac{p}{\rho g} &= \text{pressure head} \\ \frac{u^2}{2g} &= \text{velocity head} \\ z &= \text{velocity or potential head} \end{aligned}$$

3. Although above we derived the Bernoulli equation between two sections it should strictly speaking be applied along a stream line as the velocity will differ from the top to the bottom of the section. However in engineering practise it is possible to apply the Bernoulli equation with out reference to the particular streamline

The momentum equation (momentum principle)

Again consider the control volume above during the time δt

$$\begin{aligned} \text{momentum entering} &= \rho \delta Q_1 \delta t u_1 \\ \text{momentum leaving} &= \rho \delta Q_2 \delta t u_2 \end{aligned}$$

By the continuity principle : $d Q_1 = d Q_2 = d Q$

And by Newton's second law Force = rate of change of momentum

$$\begin{aligned} \delta F &= \frac{\text{momentum leaving} - \text{momentum entering}}{\delta t} \\ &= \rho \delta Q (u_2 - u_1) \end{aligned}$$

It is more convenient to write the force on a control volume in each of the three, x, y and z direction e.g. in the x-direction

$$\delta F_x = \rho \delta Q (u_{2x} - u_{1x})$$

Integration over a volume gives the total force in the x-direction as

$$F_x = \rho Q (V_{2x} - V_{1x})$$

As long as velocity V is uniform over the whole cross-section.

This is the momentum equation for steady flow for a region of uniform velocity.

Energy and Momentum coefficients

In deriving the above momentum and energy (Bernoulli) equations it was noted that the velocity must be constant (equal to V) over the whole cross-section or constant along a stream-line.

Clearly this will not occur in practice. Fortunately both these equation may still be used even for situations of quite non-uniform velocity distribution over a section. This is possible by the introduction of coefficients of energy and momentum, α and β respectively.

These are defined:

$$\alpha = \frac{\int \rho u^3 dA}{\rho V^3 A}$$

$$\beta = \frac{\int \rho u^2 dA}{\rho V^2 A}$$

where V is the mean velocity.

And the Bernoulli equation can be rewritten in terms of this mean velocity:

$$\frac{p}{\rho g} + \frac{\alpha V^2}{2g} + z = \text{constant}$$

And the momentum equation becomes:

$$F_x = \rho Q \beta (V_{2x} - V_{1x})$$

The values of α and β must be derived from the velocity distributions across a cross-section. They will always be greater than 1, but only by a small amount consequently they can often be confidently omitted – but not always and their existence should always be remembered.

For turbulent flow in regular channel α does not usually go above 1.15 and β will normally be below 1.05. We will see an example below where their inclusion is necessary to obtain accurate results.

Velocity distribution in open channels

The measured velocity in an open channel will always vary across the channel section because of friction along the boundary. Neither is this velocity distribution usually axisymmetric (as it is in pipe flow) due to the existence of the free surface. It might be expected to find the maximum velocity at the free surface where the shear force is zero but this is not the case. The maximum velocity is usually found just below the surface.

The explanation for this is the presence of secondary currents which are circulating from the boundaries towards the section centre and resistance at the air/water interface. These have been found in both laboratory measurements and 3d numerical simulation of turbulence.

The figure below shows some typical velocity distributions across some channel cross sections. The number indicates percentage of maximum velocity.

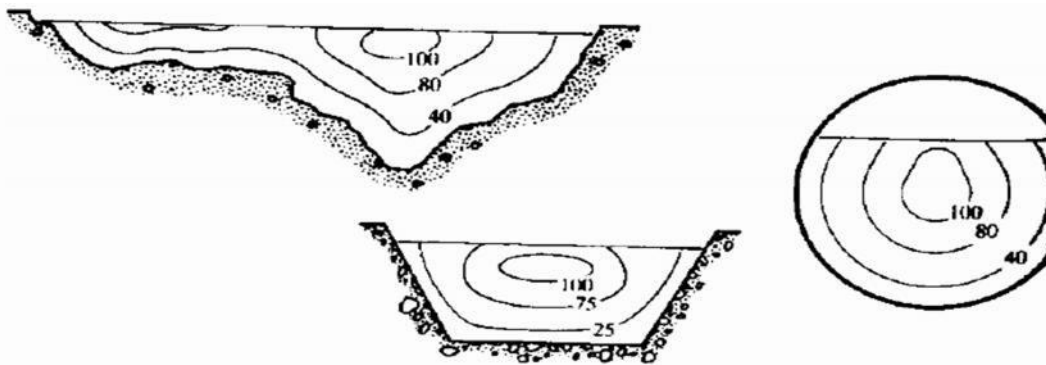

Figure of velocity distributions

Determination of energy and momentum coefficients

To determine the values of α and β the velocity distribution must have been measured (or be known in some way). In irregular channels where the flow may be divided into distinct regions α may exceed 2 and should be included in the Bernoulli equation.

The figure below is a typical example of this situation. The channel may be of this shape when a river is in flood – this is known as a compound channel.

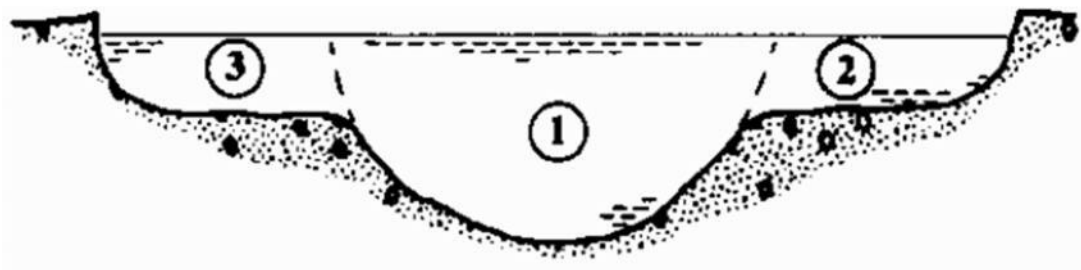

Figure of a compound channel with three regions of flow

If the channel is divided as shown into three regions and making the assumption that $\alpha = 1$ for each then

$$\alpha = \frac{\int u^3 dA}{\bar{V}^3 A} = \frac{V_1^3 A_1 + V_2^3 A_2 + V_3^3 A_3}{\bar{V}^3 (A_1 + A_2 + A_3)}$$

where

$$\bar{V} = \frac{Q}{A} = \frac{V_1 A_1 + V_2 A_2 + V_3 A_3}{A_1 + A_2 + A_3}$$

Steady Uniform flow

When uniform flow occurs gravitational forces exactly balance the frictional resistance forces which apply as a shear force along the boundary (channel bed and walls).

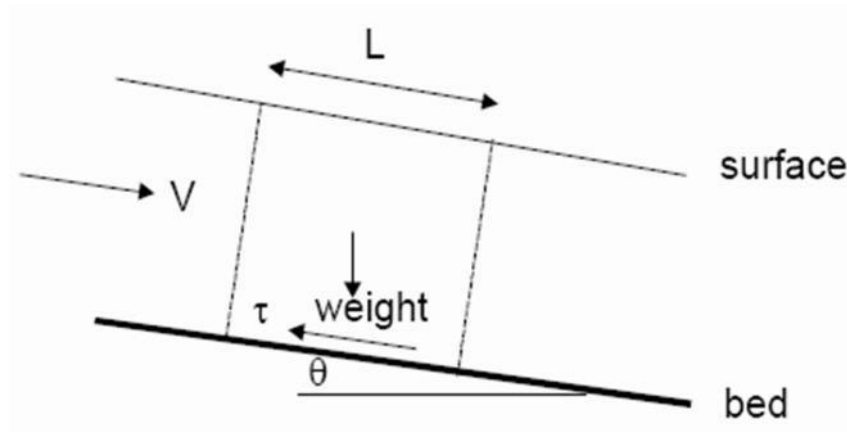

Figure of forces on a channel length in uniform flow

Considering the above diagram, the gravity force resolved in the direction of flow is

$$\text{gravity force} = \rho g A L \sin \theta$$

and the boundary shear force resolved in the direction of flow is

$$\text{shear force} = \tau_o P L$$

In uniform flow these balance $\tau_o P L = \rho g A L \sin \theta$

Considering a channel of small slope, (as channel slopes for uniform and gradually varied flow seldom exceed about 1 in 50) then

So $\sin \theta \approx \tan \theta = S_o$

$$\tau_o = \frac{\rho g A S_o}{P} = \rho g R S_o$$

The Chezy equation

If an estimate of τ_o can be made then we can make use of Equation.

If we assume the state of rough turbulent flow then we can also make the assumption the shear force is proportional to the flow velocity squared i.e.

$$\begin{aligned} \tau_o &\propto V^2 \\ \tau_o &= K V^2 \end{aligned}$$

Substituting this into equation gives

$$V = \sqrt{\frac{\rho g}{K} R S_o}$$

Or grouping the constants together as one equal to C

$$V = C\sqrt{RS_o}$$

This is the Chezy equation and the C the “Chezy C”

Because the K is not constant the C is not constant but depends on Reynolds number and boundary roughness (see discussion in previous section).

The relationship between C and f is easily seen by substituting equation 1.9 into the Darcy- Wiesbach equation written for open channels and is

$$C = \sqrt{\frac{2g}{f}}$$

The Manning equation

A very many studies have been made of the evaluation of C for different natural and manmade channels. These have resulted in today most practising engineers use some form of this relationship to give C:

$$C = \frac{R^{1/6}}{n}$$

This is known as Manning’s formula, and the n as Manning’s n . Substituting equation 1.9 in to 1.10 gives velocity of uniform flow:

Or in terms of discharge

$$V = \frac{R^{2/3} S_o^{1/2}}{n} \quad Q = \frac{1}{n} \frac{A^{5/3}}{P^{2/3}} S_o^{1/2}$$

Note:

Several other names have been associated with the derivation of this formula – or ones similar and consequently in some countries the same equation is named after one of these people. Some of these names are; Strickler, Gauckler, Kutter, Gauguillet and Hagen.

The Manning’s n is also numerically identical to the Kutter n .

The Manning equation has the great benefits that it is simple, accurate and now due to its long extensive practical use, there exists a wealth of publicly available values of n for a very wide range of channels.

Below is a table of a few typical values of Manning’s n

Channel type	Surface material and form	Manning's n range
River	earth, straight	0.02-0.025
	earth, meandering	0.03-0.05
	gravel (75-150mm), straight	0.03-0.04
	gravel (75-150mm), winding	0.04-0.08
unlined canal	earth, straight	0.018-0.025
	rock, straight	0.025-0.045
lined canal	concrete	0.012-0.017
lab. models	mortar	0.011-0.013
	Perspex	0.009

Conveyance

Channel conveyance, K , is a measure of the carrying capacity of a channel. The K is really an agglomeration of several terms in the Chezy or Manning's equation:

$$Q = AC\sqrt{RS_0}$$

$$Q = KS_0^{1/2}$$

So

$$K = ACR^{1/2} = \frac{A^{5/3}}{nP^{2/3}}$$

Use of conveyance may be made when calculating discharge and stage in compound channels and also calculating the energy and momentum coefficients in this situation.

Best Hydraulic Cross- Section

We often want to know the the minimum area A for a given flow Q , slope S_0 and roughness coef- ficient n .

This is known as the best hydraulic cross section

The quantity $AR_h^{2/3}$ in Mannings' equation is called the *section factor*

Writing the Manning equation with $R_h = A/P$, we get

$$Q = \frac{k}{n} A \left(\frac{A}{P}\right)^{2/3} S_0^{1/2} = \frac{k}{n} \frac{A^{5/3} S_0^{1/2}}{P^{2/3}}$$

Rearranged we get

$$A = \left(\frac{nQ}{kS_0^{1/2}}\right)^{3/5} P^{2/5}$$

- (inside) is a constant; Channel with minimum A is also minimum P
- Minimum excavation area A also has minimum P
- Best possible is semicircular channel, but construction costs are high

Let's find out what the best hydraulic cross section is for a rectangular channel

Example: Water flows uniformly in a rectangular channel of width b and depth y . Determine the *aspect ratio* b/y for the best hydraulic cross section.

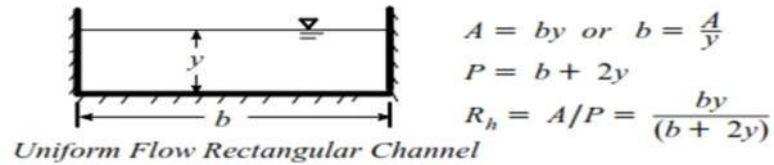

Let A be constant and let's minimize P . So

$$P = b + 2y \quad \text{or} \quad P = \frac{A}{y} + 2y$$

Thus P varies only with y for a given A . Let's take dP/dy and set to zero to find minimum

$$\frac{dP}{dy} = -\frac{A}{y^2} + 2 = 0$$

so

$$\frac{A}{y^2} = 2$$

But $A = by$, so

$$\frac{by}{y^2} = 2 \quad \text{or} \quad y = \frac{1}{2}b$$

- Thus best hydraulic cross- section for a rectangular channel occurs when the depth is one-half the width of the channel
- Note for $1 < b/y < 4$; $Q \sim .96 Q_{\max}$

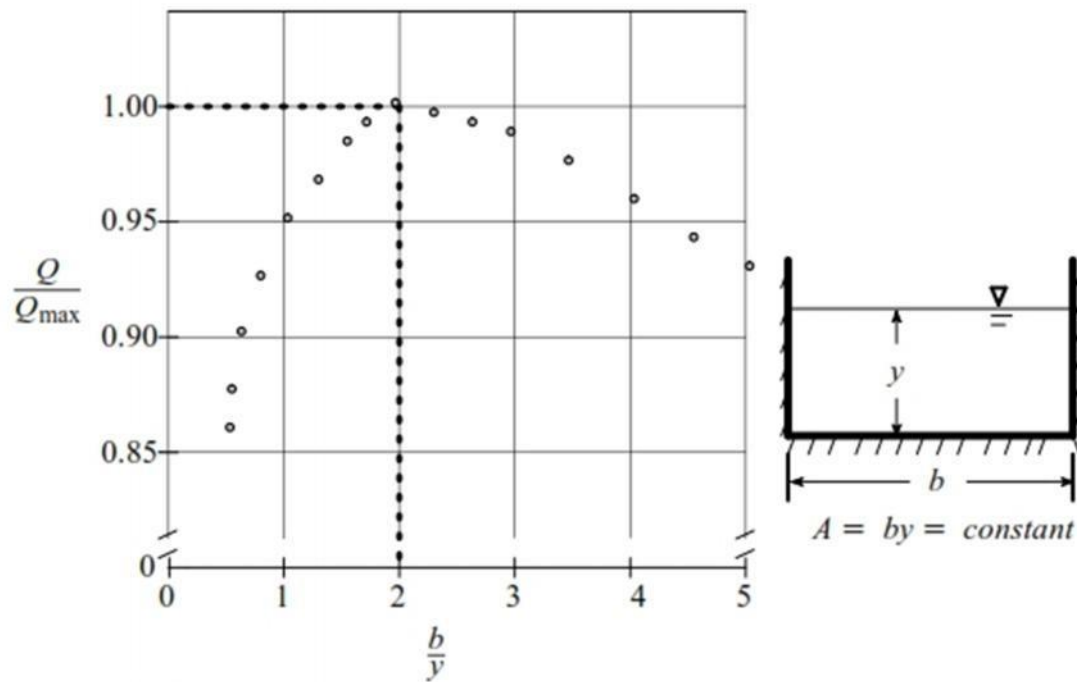

Must include freeboard f in design between 5 to 30% of y_n

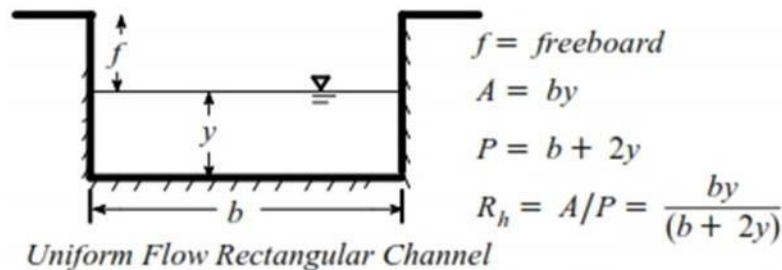

Table gives Optimum properties of Open Channel Sections

- For trapezoid, half- hexagon
- For circular section, half- circle
- For triangular section, half- square

Design of Erodible Channels

Design velocity V small enough not to cause erosion

Find maximum permissible velocity based on channel material

(Roberson, Table 4- 3)

Maximum Permissible Velocities and n Values for Different Materials		
Material	V(ft/s)	n
Fine Sand	1.50	0.020
Sandy loam	1.75	0.020
Silt loam	2.00	0.020
Firm loam	2.50	0.020
Stiff clay	3.75	0.025
Fine gravel	2.50	0.025
Coarse gravel	4.00	0.025

Assuming a trapezoidal channel, maximum side slopes depend on material (Roberson, Table 4-2)

Maximum Channel Wall Slopes for Different Materials	
Material	Side Slopes
Rock	Almost Vertical
Stiff clay or earth with concrete	1/2 : 1 to 1:1
Firm Soil	1:1
Loose sandy soil	2:1
Sandy loam soil	3:1

Once Q , V , n , S_0 are determined, solve for depth y and width b .

Problem: For an unlined trapezoidal irrigation canal in firm loam soil, slope is 0.0006 and flow is 100 cfs, what dimensions?

For side slope, pick slope of 1 1/2 (h): 1 (v) (conservative)

$$V_{\max} = 2.5 \text{ ft/s}, n = 0.020$$

To find R_h

$$V = \frac{1.49}{n} R_h^{2/3} S_0^{1/2}$$

So

$$R_h = \left(\frac{nV}{1.49} S_0^{1/2} \right)^{3/2} = \left(\frac{(0.020 \times 2.50)}{1.49 (0.0006)^{1/2}} \right)^{3/2} = 1.6 \text{ ft}$$

So for $A = Q/V$

$$A = \frac{100}{2.5} = 40 \text{ ft}^2$$

And $P = A/R_h$ so

$$P = \frac{40}{1.60} = 25 \text{ ft}$$

So if

$$A = by + 1.5y^2 \quad \text{and} \quad P = b + 3.61y$$

$$b = 18.1 \text{ ft} \quad \text{and} \quad y = 1.91 \text{ ft}$$

To construct choose $b = 18 \text{ ft}$ and $y = 2.0 \text{ ft}$.

Critical Slope

- Holding n and Q constant, changing slope will change depth and velocity
- Where velocity and depth give a Froude number = 1, this is defined as the critical slope S_c and critical depth y_c

Computations in Uniform Flow

We can use Manning's formula for discharge to calculate steady uniform flow. Two calculations are usually performed to solve uniform flow problems.

1. Discharge from a given depth
2. Depth for a given discharge

In steady uniform flow the flow depth is known as normal depth.

As we have already mentioned, and by definition, uniform flow can only occur in channels of constant cross-section (prismatic channels) so natural channel can be excluded. However we will need to use Manning's equation for gradually varied flow in natural channels - so application to natural/irregular channels will often be required.

Uniform flow Problem 1 - Discharge from depth in a trapezoidal channel

A concrete lined trapezoidal channel with uniform flow has a normal depth is 2m. The base width is 5m and the side slopes are equal at 1:2

Manning's n can be taken as 0.015 and the bed slope $S_0 = 0.001$

What are: a) Discharge (Q) b) Mean velocity (V) c) Reynolds number (Re) Calculate the section properties

$$A = (5 + 2y)y = 18m^2$$

$$P = 5 + 2y\sqrt{1 + 2^2} = 13.94m$$

Use equation to get the discharge

$$Q = \frac{1}{n} \frac{A^{5/3}}{P^{2/3}} S_o^{1/2} = \frac{1}{0.015} \frac{18^{5/3}}{13.94^{2/3}} 0.001^{1/2}$$

$$= 45m^3 / s$$

The simplest way to calculate the mean velocity is to use the continuity equation:

$$V = \frac{Q}{A} = \frac{45}{18} = 2.5m / s$$

And the Reynolds number (R=A/P)

$$Re_{channel} = \frac{\rho u R}{\mu} = \frac{\rho u A}{\mu P} = \frac{10^3 \times 2.5 \times 18}{1.14 \times 10^{-3} \times 13.94} = 2.83 \times 10^6$$

This is very large - i.e. well into the turbulent zone - the application of the Manning's equation was therefore valid.

What solution would we have obtained if we had used the Colebrook-White equation?

Probably very similar as we are well into the rough-turbulent zone where both equations are truly applicable.

To experiment an equivalent k_s value can be calculated for the discharge calculated from $n = 0.015$ and $y = 2m$ [$k_s = 2.225mm$] (Use the Colebrook-White equation and the Darcy-Wiesbach equation of open channels - both given earlier). Then a range of depths can be chosen and the discharges calculated for these n and k_s values. Comparing these discharge calculations will give some idea of the relative differences - they will be very similar.

Uniform flow Problem 2 - Depth from Discharge in a trapezoidal channel

Using the same channel as above, if the discharge is known to be $30m^3 / s$ in uniform flow, what is the normal depth?

Again use equation

$$A = (5 + 2y)y = 18m^2$$

$$P = 5 + 2y\sqrt{1 + 2^2} = 13.94m$$

$$Q = \frac{1}{0.015} \frac{((5+2y)y)^{5/3}}{(5+2y\sqrt{1+2^2})^{2/3}} 0.001^{1/2}$$

$$30 = 2.108 \frac{((5+2y)y)^{5/3}}{(5+2y\sqrt{1+2^2})^{2/3}}$$

We need to calculate y from this equation.

Even for this quite simple geometry the equation we need to solve for normal depth is complex. One simple strategy to solve this is to select some appropriate values of y and calculate the right hand side of this equation and compare it to $Q (=30)$ in the left. When it equals Q we have the correct y .

Even though there will be several solutions to this equation, this strategy generally works because we have a good idea of what the depth should be (e.g. it will always be positive and often in the range of 0.5-10 m). In this case from the previous example we know that at $Q = 45 \text{ m}^3/\text{s}$, $y = 2\text{m}$. So at $Q = 30 \text{ m}^3/\text{s}$ then $y < 2.0\text{m}$.

Gussed y (m)	Discharge Q (m^3/s)
1.7	32.7
1.6	29.1
1.63	30.1

We might also use the bisector method to solve this.

Uniform flow Problem 3 - A compound channel

If the channel in the above example were to be designed for flooding it may have a section like this:

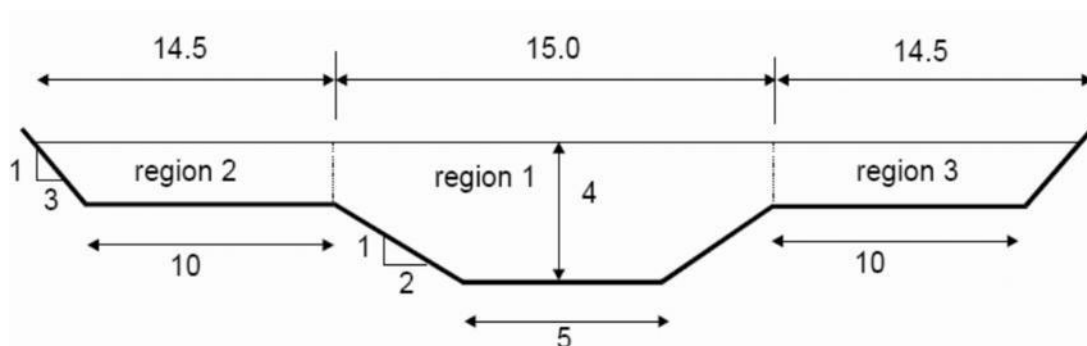

Figure of compound section

When the flow goes over the top of the trapezoidal channel it moves to the "flood plains" so the section allows for a lot more discharge to be carried.

If the flood channels are 10m wide and have side slopes of 1:3, and the Manning n on these banks is 0.035, what are a) the discharge for a flood level of 4m b) the energy coefficient a .

First split the section as shown in to three regions (this is arbitrary - left to the engineers judgement). Then apply Manning's formula for each section to give three discharge values and the total discharge will be $Q = Q_1 + Q_2 + Q_3$.

Calculate the properties of each region:

$$A_1 = \left(\frac{5+15}{2} \right) 2.5 + (15 \times 1.5) = 47.5 m^2$$

$$A_2 = A_3 = \left(\frac{10+14.5}{2} \right) 1.5 = 18.38 m^2$$

$$P_1 = 5 + (2\sqrt{5} \times 2.5) = 16.18 m$$

$$P_2 = P_3 = 10 + (1.5\sqrt{10}) = 14.75 m$$

The conveyance for each region may be calculated from equation.

$$K_1 = \frac{47.5^{5/3}}{0.015 \times 16.18^{2/3}} = 6492.5$$

$$K_2 = K_3 = \frac{18.38^{5/3}}{0.035 \times 14.74^{2/3}} = 608.4$$

And from Equations the discharges

$$Q_1 = \frac{1}{0.015} \frac{47.5^{5/3}}{16.18^{2/3}} 0.001^{1/2}$$

or

$$Q_1 = K_1 0.001^{1/2} = 205.3 m^3 / s$$

And

$$Q_2 = Q_3 = \frac{1}{0.035} \frac{18.38^{5/3}}{14.74^{2/3}} 0.001^{1/2}$$

or

$$Q_2 = Q_3 = K_2 0.001^{1/2} = 19.2 m^2 / s$$

So

$$Q = Q_1 + Q_2 + Q_3 = 243.7 m^3 / s$$

The velocities can be obtained from the continuity equation:

$$V_1 = \frac{Q_1}{A_1} = 4.32 m / s$$

$$V_2 = V_3 = \frac{Q_2}{A_2} = 1.04 m / s$$

And the energy coefficient may be obtained from Equation

$$\alpha = \frac{\int u^3 dA}{\bar{V}^3 A} = \frac{V_1^3 A_1 + V_2^3 A_2 + V_3^3 A_3}{\bar{V}^3 (A_1 + A_2 + A_3)}$$

where

$$\bar{V} = \frac{Q}{A} = \frac{V_1 A_1 + V_2 A_2 + V_3 A_3}{A_1 + A_2 + A_3}$$

Giving $\alpha = 1.9$

This is a very high value of α and a clear case of where a velocity coefficient should be used.

Not that this method does not give completely accurate relationship between stage and discharge because some of the assumptions are not accurate. E.g. the arbitrarily splitting in to regions of fixed Manning n is probably not what is occurring in the actual channel. However it will give an acceptable estimate as long as care is taken in choosing these regions.

Specific Energy

It is defined as energy per unit weight of the liquid with respect to the bottom of the channel. The extra information needed to solve the above problem can be provided by the specific energy equation. Specific energy, E_s , is defined as the energy of the flow with reference to the channel bed as the datum:

Total Energy on open channel flow

$$E = Z + y + \frac{V^2}{2g}$$

Considering the channel bed as datum line, $z=0$

$$\text{Specific Energy} = \frac{y^2}{2g} + \frac{V^2}{2g}$$

From Specific Energy curve, Corresponding to the Minimum specific energy $E(\min)$, there is only one depth of flow that is called Critical depth.

In analysing flow problems and defining critical depth, the understanding of specific energy is very useful.

In computing the total energy of flow, if the bed of the channel is taken as Datum, then the total energy of flow per unit weight will be the sum of the pressure head and velocity head. This sum is known as specific energy and is represented as

$$E = y + \frac{V^2}{2g}$$

for uniform flow E is constant

for varied flow E may decrease or increase. If bed slope i and energy correction factor α are to be included then equation (1.7) becomes

$$E = y \cos i + \alpha \frac{V^2}{2g}$$

for constant discharge through an open channel

$$E = y + \frac{Q^2}{2g A^2}$$

$E = f(y, Q)$ and when Q becomes constant,

$E = f(y)$ is represented by a cubic parabola as shown in fig.

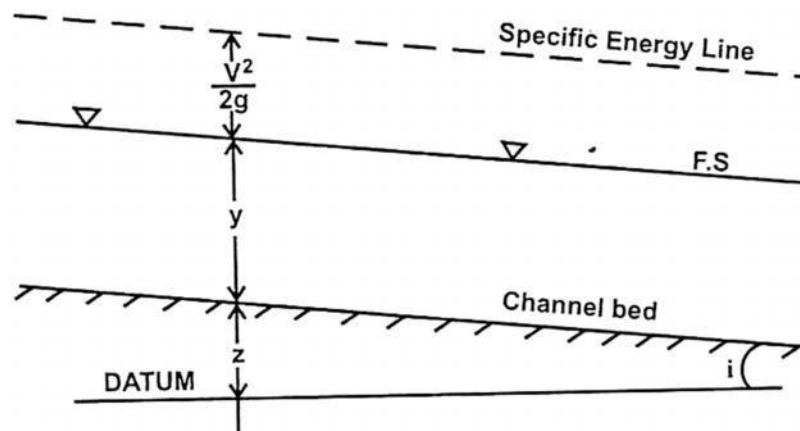
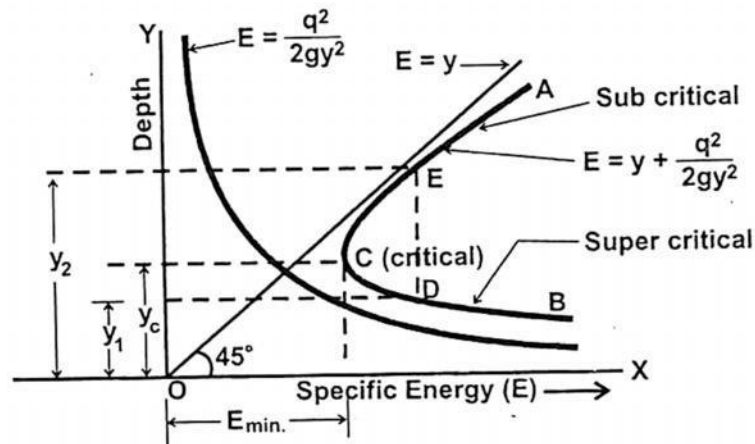

Fig. 1.7



1. Specific Energy Curve:

Specific Energy curve is defined as the curve which shows the variation of specific energy with the depth of flow.

From equation (1.7) the specific energy of flow is

$$E = y + \frac{V^2}{2g} = E_{p0.E} + E_{K.E}$$

where $E_{p0.E}$ = Pressure energy = depth of flow = Y

and $E_{K.E}$ = Kinetic energy of flow = $\frac{V^2}{2g}$.

Let a steady but non-uniform flow take place in a rectangular channel.

For steady flow this can be written in terms of discharge Q

$$E_s = y + \frac{\alpha(Q/A)^2}{2g}$$

For a rectangular channel of width b , $Q/A = q/y$

$$E_s = y + \frac{\alpha q^2}{2gy^2}$$

$$(E_s - y)y^2 = \frac{\alpha q^2}{2g} = \text{constant}$$

$$(E_s - y) = \frac{\text{constant}}{y^2}$$

This is a cubic in y . It has three solutions but only two will be positive (so discard the other).

Let 'b' be the base width of channel

Y be the depth of flow

Q be the discharge rate through the channel

q be the discharge per unit width $= \frac{Q}{b}$

$$\text{Velocity of flow } V = \frac{Q}{A} = \frac{Q}{b \times y} = \frac{q}{y}$$

Substituting in equation (1.7) we have

$$E = y + \frac{q^2}{2g y^2} = E_{PE} + E_{KE}$$

When a graph between specific energy in X-axis and y along Y-axis is plotted equation (1.10) is obtained in graphical form for various depth of flow (y). For any discharge with different depth of flow the corresponding of value can be obtained from the plot.

2. Plotting Specific Energy Curve:

Step 1: First $E_{PE} = y$ is drawn, which is a straight line inclined at an angle of 45° to x-axis.

Step 2: Draw another curve $E_{KE} = \frac{q^2}{2g y^2}$ which is a parabola is drawn.

Step 3: Combining them, specific energy curve ACB is obtained.

Critical Flow and Critical Velocity

Critical Flow

Depth of flow of water at which the specific energy, E is minimum is called as critical depth (y_c).

For rectangular channel, critical depth,

$$h_c = \left(\frac{q^2}{g} \right)^{\frac{1}{3}}$$

Critical Velocity

Velocity of flow at the critical depth is called critical velocity V_c

$$V_c = \sqrt{g y_c}$$

Where

y_c = Critical Depth

g = Acceleration due to gravity

UNIT 2 GRADUALLY VARIED FLOW

Varied Flow

Flow properties, such as depth of flow area of cross section and velocity of flow vary with respect to distance is called Non-uniform flow.

It is, otherwise, called as varied flow. The varied flow is broadly classified into two types:

- 1) Rapidly varied flow (R.V.F)
- 2) Gradually varied flow (G.V.F)

If the depth of flow changes quickly over a small length of the channel, the flow is said to be gradually varied flow (GVF). Example: Back water in a dam.

The following assumptions are made for analyzing the gradually varied flow:

1. The flow is steady
2. The pressure distribution over the channel section is hydrostatic, i.e., streamlines are practically straight and parallel.
3. The head loss is same as for uniform flow.
4. The channel slope is small, so that the depth measured vertically is the same as depth measured normal to the channel bottom.
5. A channel is prismatic.
6. Kinetic energy correction factor is very close to unity.
7. Roughness coefficient is constant along the channel length
8. The formulae, such as Chezy's formula, Manning's formula which are applicable, to the uniform flow are also applicable for the gradually varied flow for determining slope of energy line.

Gradually varied flow

In the previous section of rapidly varied flow little mention was made of losses due to friction or the influence of the bed slope. It was assumed that frictional losses were insignificant – this is reasonable because rapidly varied flow occurs over a very short distance. However when it comes to long distances they become very important, and as gradually varied flow occurs over long distances we will consider friction losses here.

In the section on specific energy it was noted that there are two depth possible in steady flow for a given discharge at any point in the channel. (One is super-critical the other depth sub-critical.) The solution of the Manning equation results in only one depth – the normal depth.

It is the inclusion of the channel slope and friction that allow us to decide which of the two depths is correct. i.e. the channel slope and friction determine whether the uniform flow in the channel is sub or super-critical.

The procedure is

- i. Calculate the normal depth from Manning's equation
- ii. Calculate the critical depth from equation

The normal depth may be greater, less than or equal to the critical depth.

For a given channel and roughness there is only one slope that will give the normal depth equal to the critical depth. This slope is known as the critical slope (S_c).

If the slope is less than S_c the normal depth will be greater than critical depth and the flow will be sub-critical flow. The slope is termed mild .

If the slope is greater than S_c the normal depth will be less than critical depth and the flow will be super-critical flow. The slope is termed steep .

Problem of critical slope calculation

We have Equation that gives normal depth and equation that given critical depth Rearranging these in terms of Q and equating gives

$$Q = \frac{1}{n} \frac{A^{5/3}}{P^{2/3}} S_o^{1/2}$$

$$\frac{\alpha Q^2 B_c}{2gA_c^3} = 1$$

$$\frac{1}{n} \frac{A^{5/3}}{P^{2/3}} S_c^{1/2} = \sqrt{\frac{gA^3}{B}}$$

For the simple case of a wide rectangular channel, width $B = b$, $A = by$ and $P = b$. And the above equation becomes

$$S_c = \frac{gn^2}{y_c^{1/3}}$$

Transitions between sub and super critical flow

If sub critical flow exists in a channel of a mild slope and this channel meets with a steep channel in which the normal depth is super-critical there must be some change of surface level between the two. In this situation the surface changes gradually between the two. The flow in the joining region is known as gradually varied flow.

This situation can be clearly seen in the figure on the left below. Note how at the point of joining of the two channels the depth passes through the critical depth.

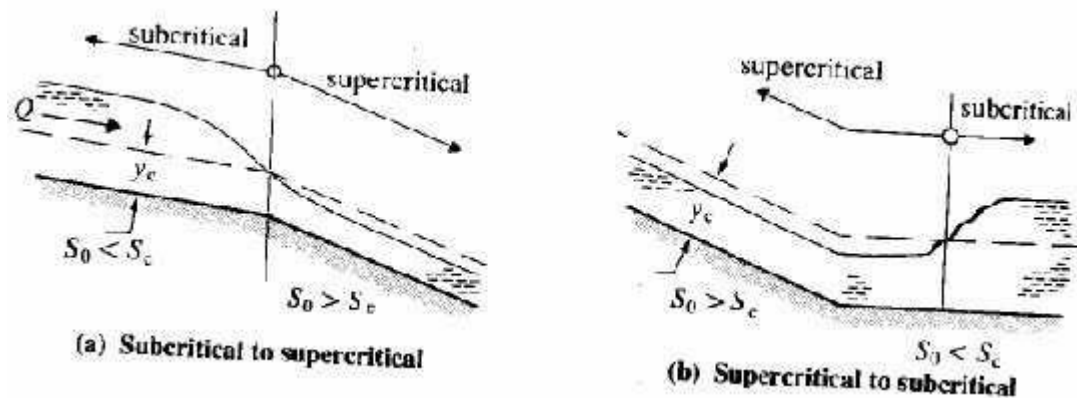

Figure of transition from sub to super-critical flow

If the situation is reversed and the upstream slope is steep, super critical flow, and the down stream mild, sub-critical, then there must occur a hydraulic jump to join the two. There may occur a short length of gradually varied flow between the channel junction and the jump. The figure above right shows this situation:

Analysis of gradually varied flow can identify the type of profile for the transition as well as the position hydraulic jumps. The equations of gradually varied flow. The basic assumption in the derivation of this equation is that the change in energy with distance is equal to the friction losses.

$$\frac{dH}{dx} = -S_f$$

The Bernoulli equation is:

$$y + \frac{\alpha V^2}{2g} + z = H$$

Differentiating and equating to the friction slope

$$\frac{d}{dx} \left(y + \frac{\alpha V^2}{2g} \right) = -\frac{dz}{dx} - S_f$$

Or

$$\frac{dE_s}{dx} = S_o - S_f$$

where S_o is the bed slope. We saw earlier how specific energy change with depth

$$\frac{dE_s}{dy} = 1 + \frac{Q^2 B_c}{g A_c^3} = 1 + Fr^2$$

Combining this with equation gives

$$\frac{dy}{dx} = \frac{S_o - S_f}{1 - Fr^2}$$

This is the basic equation of gradually varied flow. It describes how the depth, y , changes with distance x , in terms of the bed slope S_o , friction S_f and the discharge, Q , and channels shape (encompassed in Fr and S_f).

Equations 1.25 and 1.26 are differential equations equating relating depth to distance. There is no explicit solution (except for a few special cases in prismatic channels). Numerical integration is the only practical method of solution. This is normally done on computers, however it is not too cumbersome to be done by hand.

Profile Classifications

Before attempting to solve the gradually varied flow equation a great deal of insight into the type of solutions and profiles possible can be gained by taking some time to examine the equation.

Time spent over this is almost compulsory if you are to understand steady flow in open channels. For a given discharge, S_f and Fr^2 are functions of depth.

$$S_f = \frac{n^2 Q^2 P^{4/3}}{A^{10/3}}$$

$$Fr^2 = \frac{Q^2 B}{gA^3}$$

A quick examination of these two expressions shows that they both increase with A , i.e. increase with y . We also know that when we have uniform flow

$$S_f = S_o \quad \text{and} \quad y = y_n$$

So

$$S_f > S_o \quad \text{when} \quad y < y_n$$

$$S_f < S_o \quad \text{when} \quad y > y_n$$

and

$$Fr^2 > 1 \quad \text{when} \quad y < y_c$$

$$Fr^2 < 1 \quad \text{when} \quad y > y_c$$

From these inequalities we can see how the sign of dy/dx i.e. the surface slope changes for different slopes and Froude numbers.

Taking the example of a mild slope, shown in the figure below:

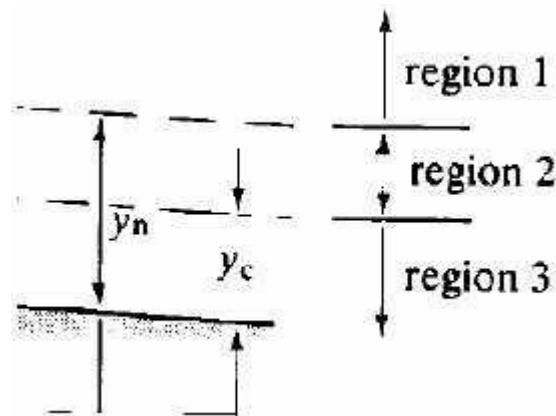

Figure of zones / regions

The normal and critical depths are shown (as it is mild normal depth is greater than critical depth). Treating the flow as to be in three zones:

- i. zone 1, above the normal depth
- ii. zone 2, between normal and critical depth
- iii. zone 3, below critical depth

The direction of the surface inclination may thus be determined.

zone 1

$$y > y_n > y_c \quad S_f < S_o \quad Fr^2 < 1 \quad \rightarrow \quad dy/dx \text{ is positive, surface rising}$$

zone 2

$$y_n > y > y_c \quad S_f > S_o \quad Fr^2 < 1 \quad \rightarrow \quad dy/dx \text{ is negative surface falling}$$

zone 3

$$y_n > y_c > y \quad S_f > S_o \quad Fr^2 > 1 \quad \rightarrow \quad dy/dx \text{ is positive surface rising}$$

The condition at the boundary of the gradually varied flow may also be determined in a similar manner:

zone 1

As $y \rightarrow \infty$ then $S_f \rightarrow S_o$ and $Fr \rightarrow 0$ and $dy/dx \rightarrow 0$

Hence the water surface is asymptotic to a horizontal line for its maximum

As $y \rightarrow y_n$ then $S_f \rightarrow S_o$ and $dy/dx \rightarrow 0$

Hence the water surface is asymptotic to the line $y = y_n$ i.e. uniform flow.

zone 2

As for zone 1 as y approached the normal depth: As $y \rightarrow y_n$ then $S_f \rightarrow S_o$ and $dy/dx \rightarrow 0$

Hence the water surface is asymptotic to the line $y = y_n$

But a problem occurs when y approaches the critical depth: As $y \rightarrow y_c$ then $Fr \rightarrow 1$ and $dy/dx \rightarrow \infty$

This is physically impossible but may be explained by the pointing out that in this region the gradually varied flow equation is not applicable because at this point the fluid is in the rapidly varied flow regime.

In reality a very steep surface will occur.

zone 3

As for zone 2 a problem occurs when y approaches the critical depth: As $y \rightarrow y_c$ then $Fr \rightarrow 1$ and $dy/dx \rightarrow \infty$

Again we have the same physical impossibility with the same explanation. And again in reality a very steep surface will occur.

As $y \rightarrow 0$ then $dy/dx \rightarrow S_o$ the slope of bed of the channel !

The gradually varied flow equation is not valid here but it is clear what occurs.

In general, normal depth is approached asymptotically and critical depth at right angles to the channel bed.

The possible surface profiles within each zone can be drawn from the above considerations. These are shown for the mild sloped channel below.

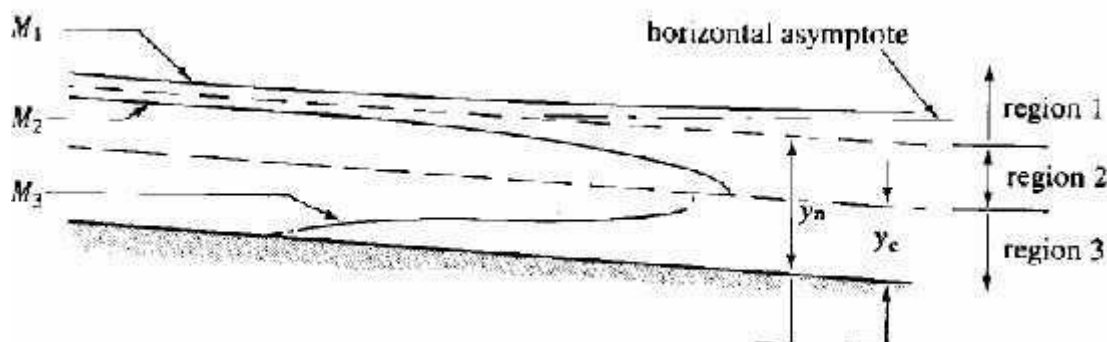

Figure of gradually varied flow surface profiles in a mild sloped channel

The surface profile in zone 1 of a mild slope is called an M1 curve, in zone 2 an M2 curve and in zone 3 an M3 curve.

All the possible surface profiles for all possible slopes of channel (there are 15 possibilities) are shown in the figure.

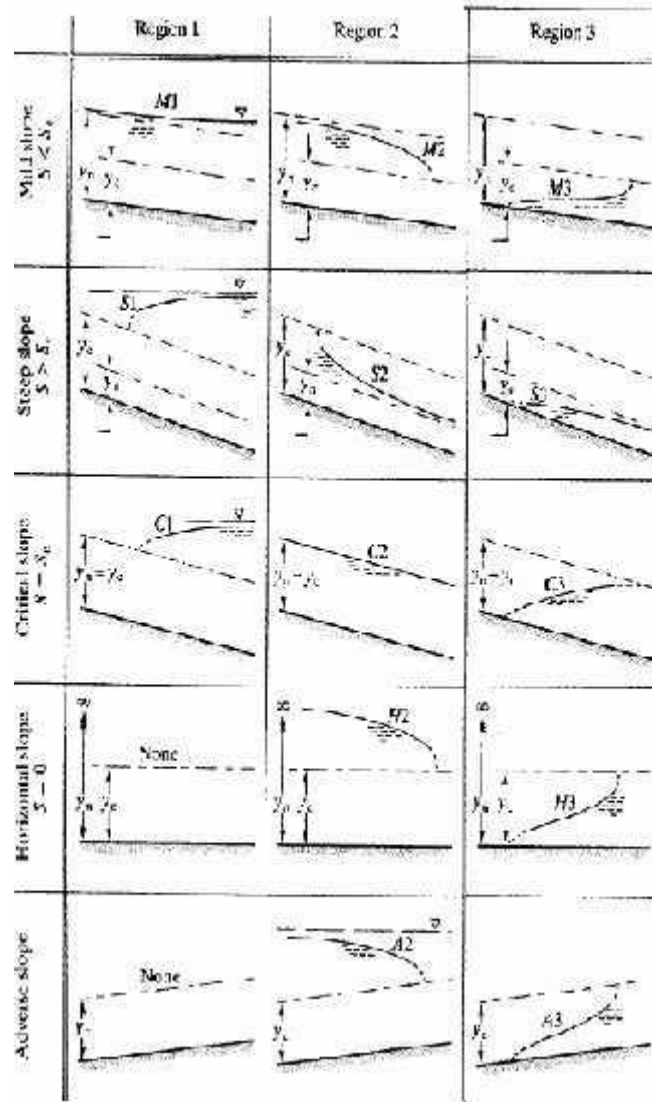

Figure of the possible gradually varied flow profiles

Surface Profiles Determination

Before one of the profiles discussed above can be decided upon two things must be determined for the channel and flow:

- Whether the slope is mild, critical or steep. The normal and critical depths must be calculated for the design discharge
- The positions of any control points must be established. Control points are points of known depth or relationship between depth and discharge. Example are weirs, flumes, gates or points where it is known critical flow occurs like at free outfalls, or that the flow is normal depth at some far distance down stream.

Once these control points and depth position has been established the surface profiles can be drawn to join the control points with the insertion of hydraulic jumps where it is necessary to join sub and super critical flows that don't meet at a critical depth.

Below are two examples.

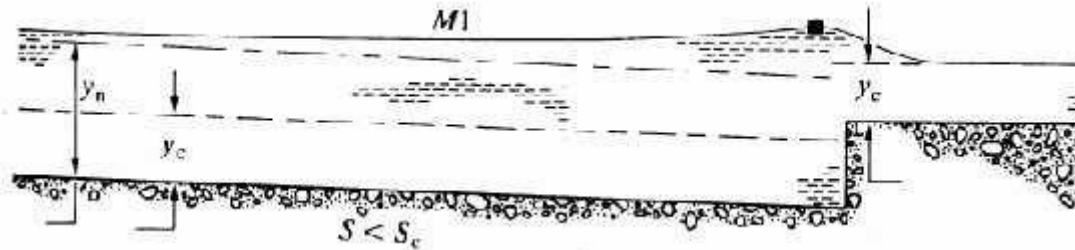

Figure of example surface profile due to a broad crested weir

This shows the control point just upstream of a broad crested weir in a channel of mild slope. The resulting curve is an M1.

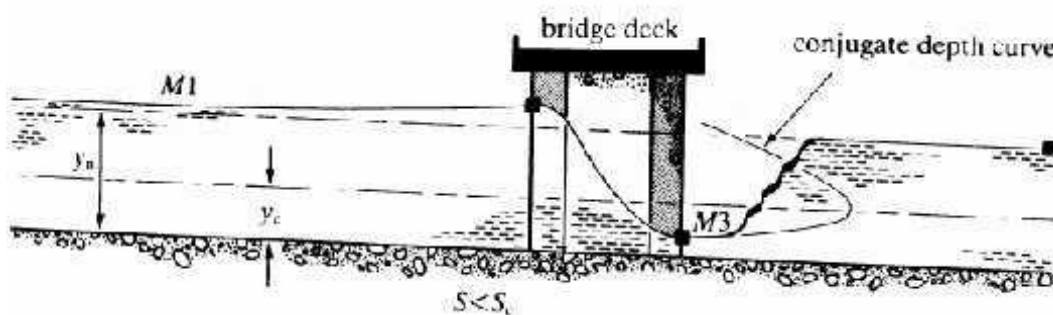

Figure of example surface profile through a bridge when in flow

This shows how a bridge may act as a control – particularly under flood conditions. Upstream there is an M1 curve then flow through the bridge is rapidly varied and the depth drops below critical depth so on exit is super critical so a short M3 curve occurs before a hydraulic jump takes the depth back to a sub-critical level. Method of solution of the gradually varied flow equation.

There are three forms of the gradually varied flow equation:

$$\frac{dH}{dx} = -S_f$$

Equation 1.26

$$\frac{dE_z}{dx} = S_o - S_f$$

Equation 1.27

$$\frac{dy}{dx} = \frac{S_o - S_f}{1 - Fr^2}$$

Equation 1.28

In the past direct and graphical solution methods have been used to solve these, however these methods have been superseded by numerical methods which are now the only method used.

Profile Determination by Numerical method

All (15) of the gradually varied flow profiles shown above may be quickly solved by simple numerical techniques. One computer program can be written to solve most situations.

There are two basic numerical methods that can be used

- i. Direct step – distance from depth
- ii. Standard step method – depth from distance

The direct step method – distance from depth

This method will calculate (by integrating the gradually varied flow equation) a distance for a given change in surface height.

The equation used is 1.28, which written in finite difference form is

$$\Delta x = \Delta y \left(\frac{1 - Fr^2}{S_o - S_f} \right)_{\text{mean}}$$

The steps in solution are:

1. Determine the control depth as the starting point
2. Decide on the expected curve and depth change if possible
3. Choose a suitable depth step Δy
4. Calculate the term in brackets at the “mean” depth ($y_{\text{initial}} + \Delta y/2$)
5. Calculate Δx
6. Repeat 4 and 5 until the appropriate distance / depth change reached

The standard step method – depth from distance

This method will calculate (by integrating the gradually varied flow equation) a depth at a given distance up or downstream.

The equation used is 1.27, which written in finite difference form is

$$\Delta E_s = \Delta x (S_o - S_f)_{\text{mean}}$$

The steps in solution are similar to the direct step method shown above but for each x there is the following iterative step:

1. Assume a value of depth y (the control depth or the last solution depth)
2. Calculate the specific energy $E_s G$
3. Calculate S_f
4. Calculate ΔE_s using equation 1.30
5. Calculate $E_s(x + \Delta x) = E_s + \Delta E_s$
6. Repeat until $\Delta E_s(x + \Delta x) = E_s G$

The Standard step method – alternative form

This method will again calculate a depth at a given distance up or downstream but this time the equation used is 1.26, which written in finite difference form is

$$\Delta H = -\Delta x (S_f)_{\text{mean}}$$

Where H is given by equation

$$y + \frac{\alpha V^2}{2g} + z = H$$

The strategy is the same as the first standard step method, with the same necessity to iterate for each step.

Graphical Integration Method

This is a simple and straight forward method and is applicable to both prismatic and non prismatic channels of any shape and slope.

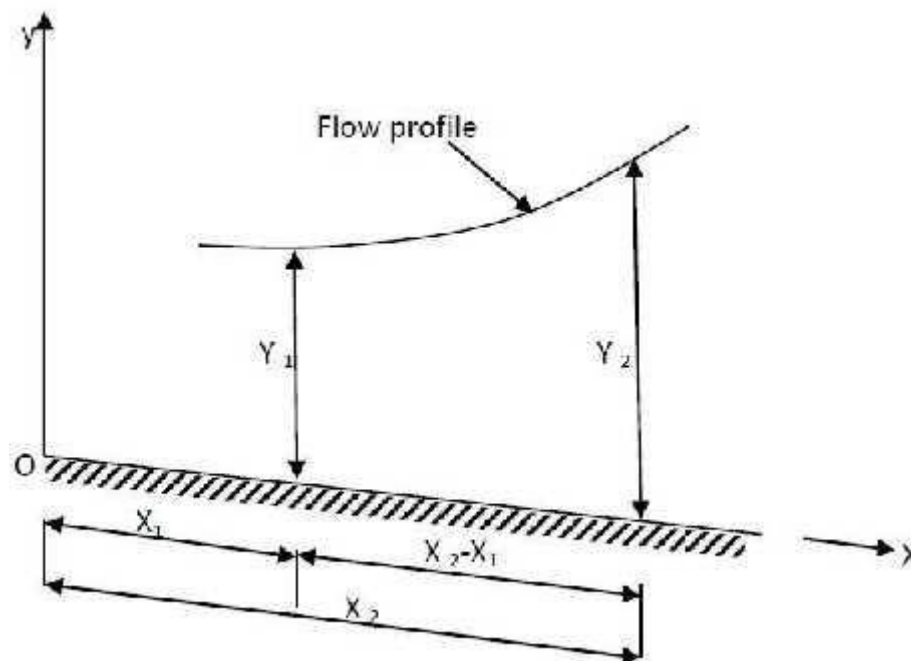

Consider two channel sections at distances x_1 and x_2 from a chosen reference O as shown in figure above. The depths of flow are y_1 and y_2 respectively; Let, $L = x_2 - x_1$, we have

$$L = x_2 - x_1 = \int_{x_1}^{x_2} dx = \int_{y_1}^{y_2} \frac{dx}{dy} dy \text{ on simplifying}$$

$$\frac{dx}{dy} = L = \int_{y_1}^{y_2} \left\{ \frac{1 - \left(\frac{z_c}{z}\right)^2}{S_0 \left\{ 1 - \left(\frac{K_{rt}}{K}\right)^2 \right\}} \right\} dy$$

The above equation can be graphically integrated for a given channel and its discharge by plotting the value of dx/dy on x-axis for various values of y plotted on x-axis.

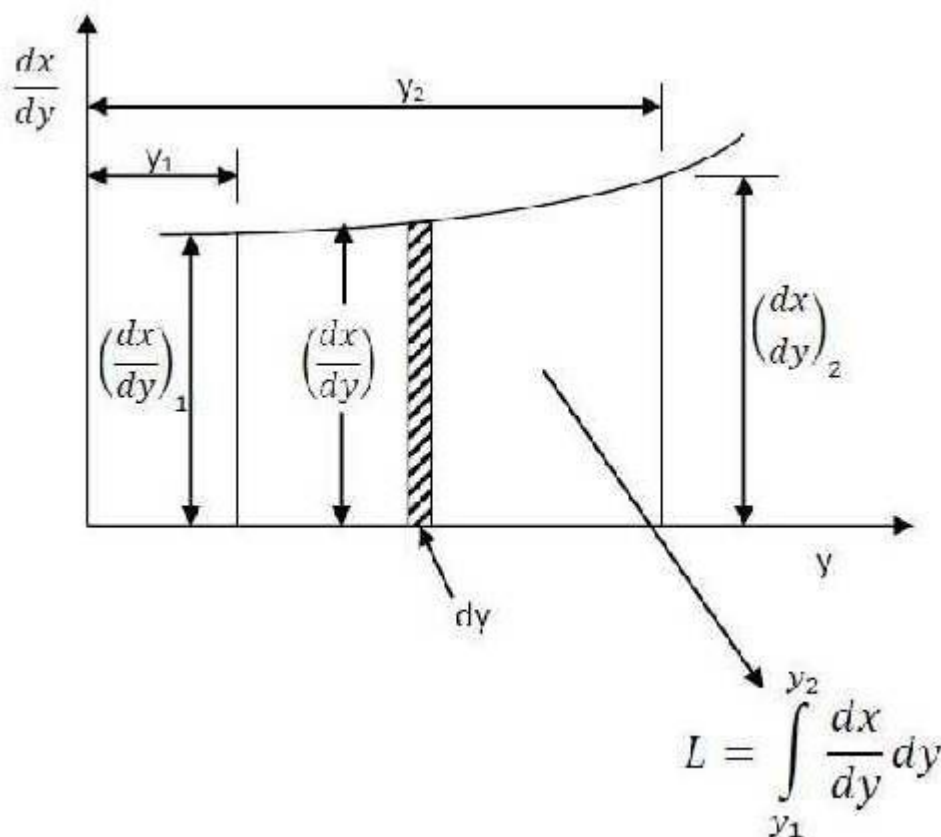

By measuring the area formed by the curve, (the x-axis and the ordinates of dx/dy at $y=y_1$ and $y=y_2$) L can be determined. The area can also be determined by computing the ordinates dx/dy for different values of y and then, calculating the area between the adjacent ordinates. Summing these areas, one can obtain the desired length L .

Problem: A river 100 m wide and 3m deep has an average bed slope of 0.0005. Estimate the length of the GVF profile produced by a low weir which raises the water surface just upstream of it by 1.5 m. Assume $N = 0.035$. Use direct step method with three steps. To estimate the length of the GVF profile

$$q = \frac{1}{n} (y_0)^{\frac{5}{3}} s_0^{\frac{1}{2}} = \frac{1}{0.035} (3)^{\frac{5}{3}} 0.0005^{\frac{1}{2}} = 3.987 \text{ m}^2 / \text{sec}$$

$$\text{Critical depth } y_c = \left(\frac{q^2}{g} \right)^{\frac{1}{3}} = \left(\frac{3.987^2}{9.81} \right)^{\frac{1}{3}} = 1.175 \text{ m}$$

since $y > y_0 > y_c$. The GVF profile is an M_1 curve with Curve with the depth

$$y = 4.5 \text{ m}$$

Use Three Steps

$$\frac{4.5 - 3.0}{3.0} = 0.5 \text{ m}$$

$$q = \frac{Q}{b}$$

$$Q = q \times b = 3.987 \times 100 = 398.70 \text{ m}^3 / \text{sec}$$

Problem: In a rectangular channel of bed width 0.5 m, a hydraulic jump occurs at a point where depth of flow is 0.15 m and Froude's number is 2.5. Determine (1) The specific energy (2) The critical depth (3) The subsequent depths (4) Loss of head (5) Energy dissipated.

Given Data

$$b = 0.5 \text{ m}$$

$$y = 0.15 \text{ m}$$

$$F = 2.5$$

Solution:

Step-1: To Determine the Specific Energy:

$$E = y + \frac{V^2}{2g} = y + \frac{Q^2}{V^2 \times 2g} \quad \text{note : } V = \frac{Q}{A}$$

$$F = \frac{V}{\sqrt{gD}}$$

$$\text{note : } D = \frac{A}{T} = \frac{b \times y}{b} = y$$

$$F = \frac{V}{\sqrt{gy}}$$

$$2.5 = \frac{V}{\sqrt{g \times 0.15}}$$

From Equation 1, we can Get

$$E = y + \frac{V^2}{2g} = 0.15 + \frac{3.033^2}{2 \times 9.81} = 0.619 \text{ m}$$

Step-2: To Determine the Critical Depth:

$$h_c = \left(\frac{q^2}{g} \right)^{\frac{1}{3}}$$

$$q = \frac{Q}{b} = \frac{A \times V}{b} = \frac{(b \times d) \times V}{b} = V \times d$$
$$= 3.033 \times 0.15$$

$$q = 0.455 \text{ m}^2 / \text{sec}$$

$$h_c = \left(\frac{q^2}{g} \right)^{\frac{1}{3}} = \left(\frac{0.455^2}{9.81} \right)^{\frac{1}{3}} = 0.276 \text{ m}$$

UNIT 3 RAPIDLY VARIED FLOW

The Application of the Energy equation for Rapidly Varied Flow

Rapid changes in stage and velocity occur whenever there is a sudden change in cross-section, a very steep bed-slope or some obstruction in the channel. This type of flow is termed rapidly varied flow .

Typical examples are flow over sharp-crested weirs and flow through regions of greatly changing cross-section (Venturi flumes and broad-crested weirs). Rapid change can also occur when there is a change from super-critical to sub-critical flow (see later) in a channel reach at a hydraulic jump.

In these regions the surface is highly curved and the assumptions of hydrostatic pressure distribution and parallel streamlines do not apply. However it is possible to get good approximate solutions to these situations yet still use the energy and momentum concepts outlined earlier. The solutions will usually be sufficiently accurate for engineering purposes.

The energy (Bernoulli) equation

The figure below shows a length of channel inclined at a slope of θ and flowing with uniform flow.

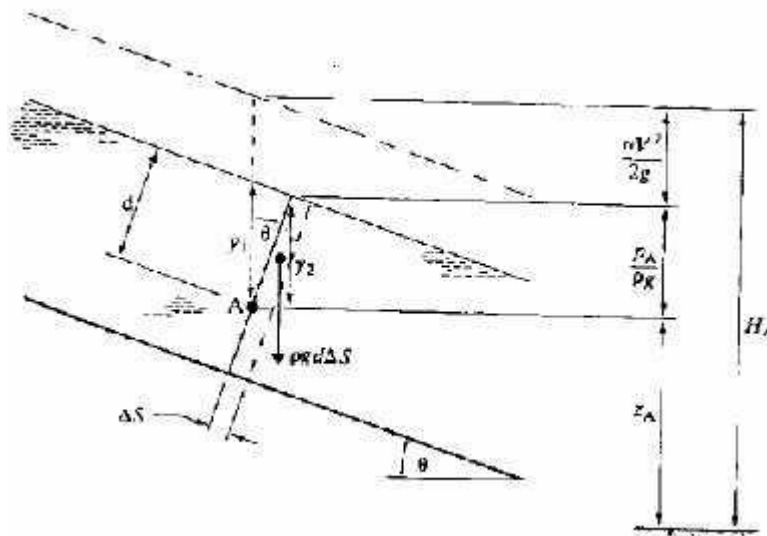

Figure of channel in uniform flow

Recalling the Bernoulli equation

$$\frac{p}{\rho g} + \frac{\alpha V^2}{2g} + z = \text{constant}$$

And assuming a hydrostatic pressure distribution we can write the pressure at a point on a streamline, A say, in terms of the depth d (the depth measured from the water surface in a direction normal to the bed) and the channel slope.

$$p_A = \rho g d$$

In terms of the vertical distance

$$d = \frac{y_2}{\cos \theta} = y_1 \cos \theta$$

$$y_2 = y_1 \cos^2 \theta$$

So

$$p_A = \rho g y_1 \cos^2 \theta$$

So the pressure term in the above Bernoulli equation becomes

$$\frac{p_A}{\rho g} = y_1 \cos^2 \theta$$

As channel slope in open channel are very small (1:100 = 0.57 and = 0.9999) so unless the channel is unusually steep \cos^2

$$\frac{p_A}{\rho g} = y_1$$

And the Bernoulli equation becomes

$$y + \frac{\alpha V^2}{2g} + z = H$$

Critical, Sub-critical and super critical flow

The specific energy change with depth was plotted above for a constant discharge Q , it is also possible to plot a graph with the specific energy fixed and see how Q changes with depth. These two forms are plotted side by side below.

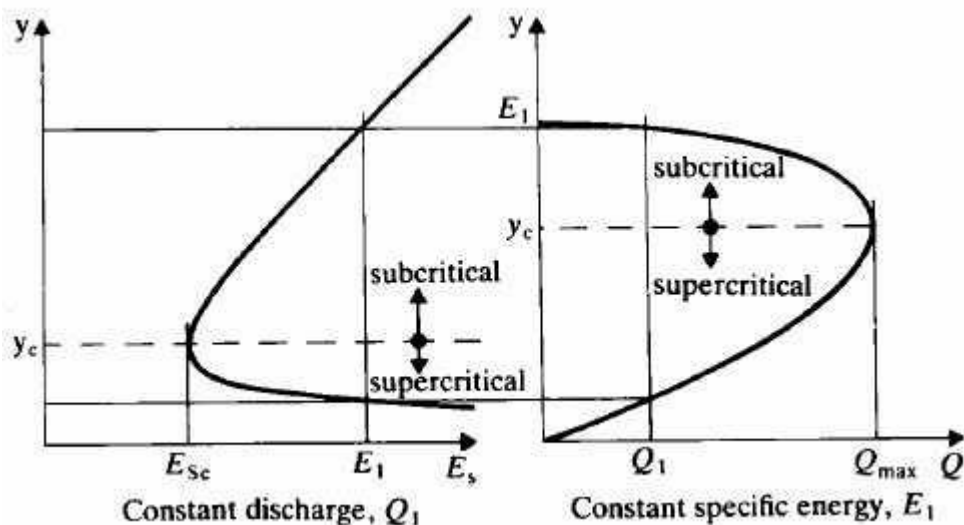

Figure of variation of Specific Energy and Discharge with depth

From these graphs we can identify several important features of rapidly varied flow.

For a fixed discharge:

1. The specific energy is a minimum, E_{sc} , at depth y_c , This depth is known as critical depth.
2. For all other values of E_s there are two possible depths. These are called alternate depths. For

subcritical flow $y > y_c$

supercritical flow $y < y_c$

For a fixed Specific energy

1. The discharge is a maximum at critical depth, y_c
 2. For all other discharges there are two possible depths of flow for a particular E_s
- i.e. There is a sub-critical depth and a super-critical depth with the same E_s

An equation for critical depth can be obtained by setting the differential of E_s to zero:

$$E_s = y + \frac{\alpha(Q/A)^2}{2g}$$

$$\frac{dE_s}{dy} = 0 = 1 + \frac{\alpha Q^2}{2g} \frac{d}{dA} \left(\frac{1}{A^2} \right) \frac{dA}{dy}$$

Since $\delta A = B \delta y$, in the limit $dA/dy = B$ and

$$0 = 1 - \frac{\alpha Q^2}{2g} B_c 2A_c^{-3}$$

$$\frac{\alpha Q^2 B_c}{g A_c^3} = 1$$

For a rectangular channel $Q = qb$, $B = b$ and $A = by$, and taking $\alpha = 1$ this equation becomes

$$y_c = \left(\frac{q}{g} \right)^{1/3}$$

as $V_c y_c = q$

$$V_c = \sqrt{g y_c}$$

Substituting this in to the specific energy equation

$$E_{sc} = y_c + \frac{V_c^2}{2g} = y_c + \frac{y_c}{2}$$

$$y_c = \frac{2}{3} E_{sc}$$

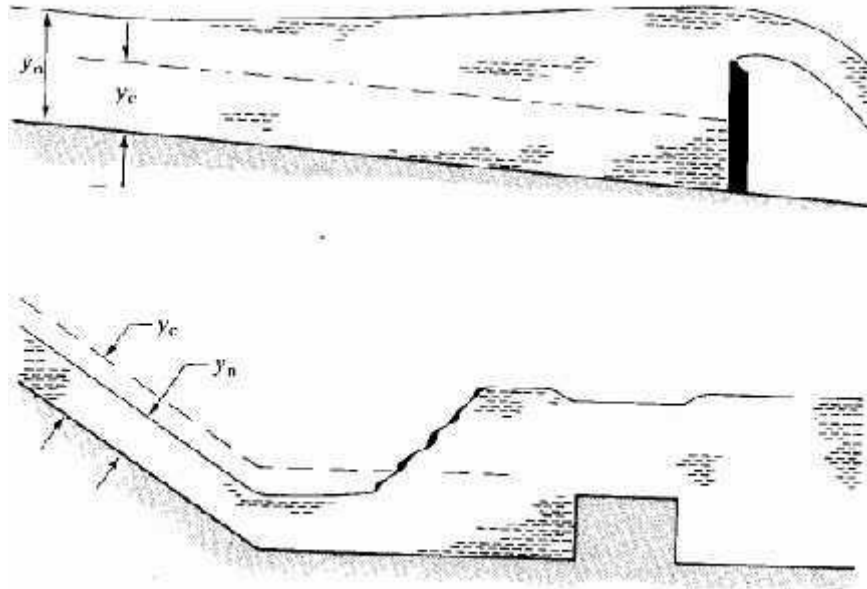

Figure of sub and super critical flow and transmission of disturbances

Application of the Momentum equation for Rapidly Varied Flow

The hydraulic jump is an important feature in open channel flow and is an example of rapidly varied flow. A hydraulic jump occurs when a super-critical flow and a sub-critical flow meet. The jump is the mechanism for the to surface to join. They join in an extremely turbulent manner which causes large energy losses.

Because of the large energy losses the energy or specific energy equation cannot be used in analysis, the momentum equation is used instead.

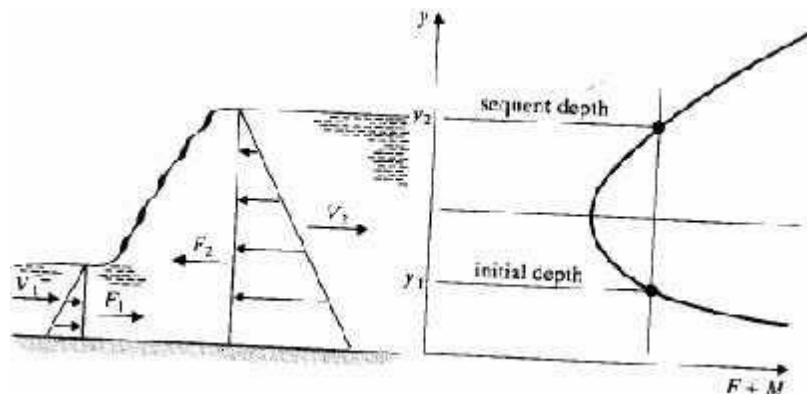

Figure of forces applied to the control volume containing the hydraulic jump

Resultant force in x- direction = $F_1 - F_2$

Momentum change = $M_2 - M_1$

$$F_1 - F_2 = M_2 - M_1$$

Or for a constant discharge

$$F_1 + M_1 = F_2 + M_2 = \text{constant}$$

For a rectangular channel this may be evaluated using

$$\begin{aligned} F_1 &= \rho g \frac{y_1}{2} y_1 b & F_2 &= \rho g \frac{y_2}{2} y_2 b \\ M_1 &= \rho Q V_1 & M_2 &= \rho Q V_2 \\ &= \rho Q \frac{Q}{y_1 b} & &= \rho Q \frac{Q}{y_2 b} \end{aligned}$$

Substituting for these and rearranging gives

$$y_2 = \frac{y_1}{2} \left(\sqrt{1 + 8Fr_1^2} - 1 \right)$$

Or

$$y_1 = \frac{y_2}{2} \left(\sqrt{1 + 8Fr_2^2} - 1 \right)$$

So knowing the discharge and either one of the depths on the upstream or downstream side of the jump the other – or conjugate depth – may be easily computed.

More manipulation with Equation and the specific energy give the energy loss in the jump as

$$\Delta E = \frac{(y_2 - y_1)^3}{4y_1 y_2}$$

These are useful results and which can be used in gradually varied flow calculations to determine water surface profiles.

In summary, a hydraulic jump will only occur if the upstream flow is super-critical. The higher the upstream Froude number the higher the jump and the greater the loss of energy in the jump.

Hydraulic jump

A hydraulic jump is a phenomenon in the science of hydraulics which is frequently observed in open channel flow such as rivers and spillways. When liquid at high velocity discharges into a zone of lower velocity, a rather abrupt rise occurs in the liquid surface. The rapidly flowing liquid is abruptly slowed and increases in height, converting some of the flow's initial kinetic energy into an increase in potential energy, with some energy irreversibly lost through turbulence to heat. In an open channel flow, this manifests as the fast flow rapidly slowing and piling up on top of itself similar to how a shockwave forms.

Expression for Hydraulic Jump

$$y_2 = \frac{y_1}{2} \left(\sqrt{1 + 8(F_1)^2} - 1 \right)$$

Where

Y1	=	depth of flow at section 1-1
Y2	=	depth of flow at section 2-2
F1	=	Froude number at section 1-1

Loss of Energy due to Hydraulic Jump

$$h_f = \frac{y_2 - y_1}{4y_1 y_2} (y_2 - y_1)^3$$

Where

Y ₁	=	depth of flow at section 1-1
Y ₂	=	depth of flow at section 2-2

Uses of Hydraulic Jump

The kinetic energy of flow after the hydraulic jump is greatly reduced, which may prevent erosion of the channel boundaries of downstream side.

Classification of Hydraulic Jumps

Based on Froude number (F), hydraulic jump can be classified into 5 types.

- Undulation jump: The Froude number F ranges from 1 to 1.7 and the liquid surface does not rise shortly but having undulations of radically decreasing size.
- Weak jump: The Froude number F ranges from 1.7 to 2.5 and the liquid surface remains smooth.
- Oscillating jump: The Froude number F ranges from 2.5 to 4.5 and there is an oscillating jet which enters the jump bottom and oscillating to the surface.
- Steady jump: The Froude number F ranges from 4.5 to 9 and energy loss due to steady jump in between 45 and 70%.
- Strong jump: The Froude number greater than 9 and the downstream water surface is rough. Energy loss due to strong jump may be up to 85%.

Problem : Find the slope of the free water surface of a rectangular stream 15 m. Wide and 3m deep. The bed slope of the stream is 1 in 5000. Total discharge is 29 m³/s. Assume C = 65 and the depth is increasing in the direction of flow.

Solution:

$$V = \frac{Q}{A} = \frac{29}{15 \times 3} = 0.645 \text{ m/s}$$

$$F^2 = \frac{V^2}{g y} = \frac{0.645^2}{9.81 \times 3} = 0.0142$$

$$S_c = \frac{V^2}{C^2 R} \quad \left[\because V = C \sqrt{m i} = C \sqrt{R S_e} \therefore R = \frac{A}{P} = \frac{15 \times 3}{15 + 3 + 3} = \frac{45}{21} \right]$$

$$= \frac{0.645^2}{65^2 \times \frac{45}{21}}$$

$$S_c = \frac{1}{21700}$$

$$\frac{dy}{dx} = \frac{S_0 - S_e}{1 - F^2} = \frac{\frac{1}{5000} - \frac{1}{21700}}{(1 - 0.0142)}$$

$$\frac{dy}{dx} = \frac{1}{6400}$$

\therefore Slope of free water surface is 1 in 6400.

UNIT 4 TURBINES

Introduction

Most of the electrical generators are powered by turbines. Turbines are the primemovers of civilisation. Steam and Gas turbines share in the electrical power generation is about 75%. About 20% of power is generated by hydraulic turbines and hence their importance. Rest of 5% only is by other means of generation.

Hydraulic power depends on renewable source and hence is ever lasting. It is also non polluting in terms of non generation of carbon dioxide.

Breaking Jet

When the nozzle is completely closed, the amount of water striking the runner reduces to zero but the runner due to inertia goes on revolving for a long time to stop the runner in a short time a small nozzle is provided which direct the jet of water on the back of vanes. This jet of water is called breaking jet.

Classification of Turbines

The main classification depends upon the type of action of the water on the turbine. These are

(i) **Impulse turbine** (ii) **Reaction Turbine.**

(i) In the case of impulse turbine all the potential energy is converted to kinetic energy in the nozzles. The impulse provided by the jets is used to turn the turbine wheel. The pressure inside the turbine is atmospheric.

This type is found suitable when the available potential energy is high and the flow available is comparatively low. Some people call this type as tangential flow units. Later discussion will show under what conditions this type is chosen for operation.

(ii) In reaction turbines the available potential energy is progressively converted in the turbines rotors and the reaction of the accelerating water causes the turning of the wheel.

These are again divided into radial flow, mixed flow and axial flow machines. Radial flow machines are found suitable for moderate levels of potential energy and medium quantities of flow. The axial machines are suitable for low levels of potential energy and large flow rates. The potential energy available is generally denoted as "head available". With this terminology plants are designated as "high head", "medium head" and "low head" plants.

Impulse and reaction turbines

Turbines work in two different ways described as impulse and reaction terms that are often very confusingly described (and sometimes completely muddled up) when people try to explain them. So what's

the difference?

Impulse turbines

In an impulse turbine, a fast-moving fluid is fired through a narrow nozzle at the turbine blades to make them spin around. The blades of an impulse turbine are usually bucket-shaped so they catch the fluid and direct it off at an angle or sometimes even back the way it came (because that gives the most efficient transfer of energy from the fluid to the turbine). In an impulse turbine, the fluid is forced to hit the turbine at high speed. Imagine trying to make a wheel like this turn around by kicking soccer balls into its paddles. You'd need the balls to hit hard and bounce back well to get the wheel spinning—and those constant energy impulses are the key to how it works.

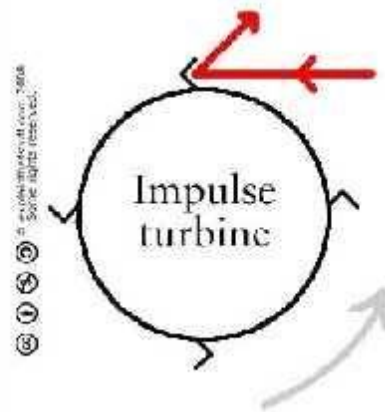

impulse turbine

Reaction turbines

In a reaction turbine, the blades sit in a much larger volume of fluid and turn around as the fluid flows past them. A reaction turbine doesn't change the direction of the fluid flow as drastically as an impulse turbine: it simply spins as the fluid pushes through and past its blades.

If an impulse turbine is a bit like kicking soccer balls, a reaction turbine is more like swimming—in reverse. Let me explain! Think of how you do freestyle (front crawl) by hauling your arms through the water, starting with each hand as far in front as you can reach and ending with a "follow through" that throws your arm well behind you.

What you're trying to achieve is to keep your hand and forearm pushing against the water for as long as possible, so you transfer as much energy as you can in each stroke. A reaction turbine is using the same idea in reverse: imagine fast-flowing water moving past you so it makes your arms and legs move and supplies energy to your body! With a reaction turbine, you want the water to touch the blades smoothly, for as long as it can, so it gives up as much energy as possible. The water isn't hitting the blades and bouncing off, as it does in an impulse turbine: instead, the blades are moving more smoothly, "going with the flow".

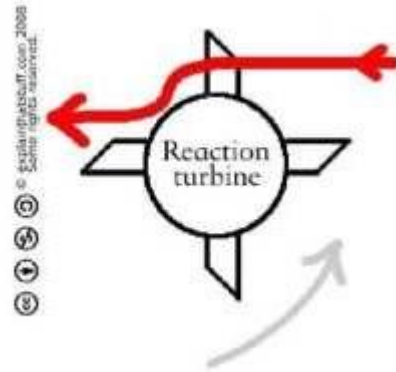

reaction turbine

Turbines in action

Broadly speaking, we divide turbines into four kinds according to the type of fluid that drives them: water, wind, steam, and gas. Although all four types work in essentially the same way—spinning around as the fluid moves against them—they are subtly different and have to be engineered in very different ways. Steam turbines, for example, turn incredibly quickly because steam is produced under high-pressure. Wind turbines that make electricity turn relatively slowly (mainly for safety reasons), so they need to be huge to capture decent amounts of energy. Gas turbines need to be made from specially resilient alloys because they work at such high temperatures. Water turbines are often very big because they have to extract energy from an entire river, dammed and diverted to flow past them.

Kaplan turbine

The Kaplan turbine is a propeller-type water turbine which has adjustable blades. It was developed in 1913 by the Austrian professor Viktor Kaplan, who combined automatically - adjusted propeller blades with automatically-adjusted wicket gates to achieve efficiency over a wide range of flow and water level.

The Kaplan turbine was an evolution of the Francis turbine. Its invention allowed efficient power production in low-head applications that was not possible with Francis turbines.

Kaplan turbines are now widely used throughout the world in high-flow, low-head power production. The Kaplan turbine is an inward flow reaction turbine, which means that the working fluid changes pressure as it moves through the turbine and gives up its energy. The design combines radial and axial features.

The inlet is a scroll-shaped tube that wraps around the turbine's wicket gate. Water is directed tangentially through the wicket gate and spirals on to a propeller shaped runner, causing it to rotate. The outlet is a specially shaped draft tube that helps decelerate the water and recover kinetic energy.

The turbine does not need to be at the lowest point of water flow as long as the draft tube remains full of water. A higher turbine location, however, increases the suction that is imparted on the turbine blades by

the draft tube. The resulting pressure drop may lead to cavitation.

Variable geometry of the wicket gate and turbine blades allow efficient operation for a range of flow conditions. Kaplan turbine efficiencies are typically over 90%, but may be lower in very low head applications.

Current areas of research include CFD driven efficiency improvements and new designs that raise survival rates of fish passing through.

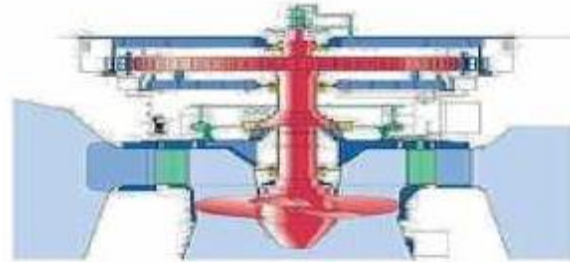

Applications

Kaplan turbines are widely used throughout the world for electrical power production. They cover the lowest head hydro sites and are especially suited for high flow conditions. Inexpensive micro turbines are manufactured for individual power production with as little as two feet of head. Kaplan turbine is low head turbine. Large Kaplan turbines are individually designed for each site to operate at the highest possible efficiency, typically over 90%. They are very expensive to design, manufacture and install, but operate for decades.

Problem: A Kaplan turbine works under a head of 26.5 m, the flow rate of water being 170 m³/s. The overall efficiency is 90%. Determine the power and specific speed. The turbine speed is 150 rpm.

Solution:

$$\begin{aligned} \text{Power developed} &= 0.9 \times 170 \times 10^3 \times 9.81 \times 26.5 \\ W &= 39.77 \times 10^6 \text{ W or } 39.77 \text{ MW} \end{aligned}$$

Dimensionless specific speed

$$\begin{aligned} &= \frac{N\sqrt{P}}{\rho^{1/2}(gH)^{5/4}} = \frac{150}{60} \cdot \frac{\sqrt{39.77 \times 10^6}}{1000^{1/2} \times 9.81^{1.25} \times 26.5^{1.25}} = 0.4776 \text{ rad} \end{aligned}$$

Dimensional specific speed

$$= \frac{150}{60} \cdot \frac{\sqrt{39.77 \times 10^6}}{26.5^{1.25}} = 262.22$$

Problem : A Kaplan turbine plant develops 3000 kW under a head of 10 m. While running at 62.5 rpm. The

discharge is 350 m³/s. The tip diameter of the runner is 7.5 m and the hub to tip ratio is 0.43. Calculate the specific speed, turbine efficiency, the speed ratio and flow ratio.

Speed ratio is based on tip speed. Hub diameter = $0.43 \times 7.5 = 3.225$ m Turbine efficiency = $P / \rho Q H g$

$$= \frac{30000 \times 10^3}{1000 \times 350 \times 10 \times 9.81} = 0.8737 \text{ or } 87.37\%$$

$$\text{Specific speed} = \frac{60}{60} \cdot \frac{\sqrt{30,000 \times 10^3}}{10^{1.25}} = 308$$

$$\text{Runner tip speed} = \frac{\pi \times 7.5 \times 60}{60} = 23.56 \text{ m/s}$$

$$\therefore \text{Speed ratio} = 23.56 / \sqrt{2 \times 9.81 \times 10} = 1.68$$

$$\text{Flow velocity} = \frac{350 \times 4}{\pi (7.5^2 - 3.225^2)} = 9.72 \text{ m/s}$$

$$\therefore \text{Flow ratio} = 9.72 / \sqrt{2 \times 9.81 \times 10} = 0.69.$$

Variations

The Kaplan turbine is the most widely used of the propeller-type turbines, but several other variations exist:

Propeller Turbines

Propeller Turbines have non-adjustable propeller vanes. They are used in where the range of head is not large. Commercial products exist for producing several hundred watts from only a few feet of head. Larger propeller turbines produce more than 100 MW.

Bulb or Tubular turbines

Bulb or Tubular turbines are designed into the water delivery tube. A large bulb is centered in the water pipe which holds the generator, wicket gate and runner. Tubular turbines are a fully axial design, whereas Kaplan turbines have a radial wicket gate.

Pit turbines

Pit turbines are bulb turbines with a gear box. This allows for a smaller generator and bulb. Straflo turbines are axial turbines with the generator outside of the water channel, connected to the periphery of the runner.

S- turbines

S- turbines eliminate the need for a bulb housing by placing the generator outside of the water channel. This is accomplished with a jog in the water channel and a shaft connecting the runner and generator.

Tyson turbines

Tyson turbines are a fixed propeller turbine designed to be immersed in a fast flowing river, either permanently anchored in the river bed, or attached to a boat or barge.

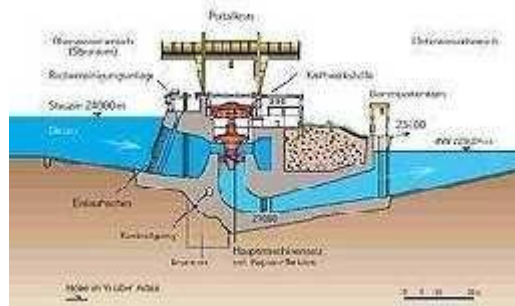

Francis Turbine

The **Francis turbine** is a type of water turbine that was developed by James B. Francis in Lowell, MA. It is an inward-flow reaction turbine that combines radial and axial flow concepts.

Francis turbines are the most common water turbine in use today. They operate in a head range of ten meters to several hundred meters and are primarily used for electrical power production.

The inlet is spiral shaped. Guide vanes direct the water tangentially to the turbine wheel, known as a runner. This radial flow acts on the runner's vanes, causing the runner to spin. The guide vanes (or wicket gate) may be adjustable to allow efficient turbine operation for a range of water flow conditions.

As the water moves through the runner, its spinning radius decreases, further acting on the runner. For an analogy, imagine swinging a ball on a string around in a circle; if the string is pulled short, the ball spins faster due to the conservation of angular momentum. This property, in addition to the water's pressure, helps Francis and other inward-flow turbines harness water energy efficiently. Water wheels have been used historically to power mills of all types, but they are inefficient.

Nineteenth-century efficiency improvements of water turbines allowed them to compete with steam engines (wherever water was available).

In 1826 Benoit Fourneyron developed a high efficiency (80%) outward-flow water turbine. Water was directed tangentially through the turbine runner, causing it to spin. Jean - Victor Poncelet designed an inward-flow turbine in about 1820 that used the same principles. In 1848 James B. Francis, while working as head engineer of the Locks and Canals company in the water-powered factory city of Lowell, Massachusetts, improved on these designs to create a turbine with 90% efficiency. He applied scientific principles and testing methods to produce a very efficient turbine design. More importantly, his mathematical

and graphical calculation methods improved turbine design and engineering. His analytical methods allowed confident design of high efficiency turbines to exactly match a site's flow conditions.

The Francis turbine is a reaction turbine, which means that the working fluid changes pressure as it moves through the turbine, giving up its energy. A casement is needed to contain the water flow. The turbine is located between the high-pressure water source and the low-pressure water exit, usually at the base of a dam.

The inlet is spiral shaped. Guide vanes direct the water tangentially to the turbine wheel, known as a runner. This radial flow acts on the runner's vanes, causing the runner to spin. The guide vanes (or wicket gate) may be adjustable to allow efficient turbine operation for a range of water flow conditions.

As the water moves through the runner, its spinning radius decreases, further acting on the runner. For an analogy, imagine swinging a ball on a string around in a circle; if the string is pulled short, the ball spins faster due to the conservation of angular momentum. This property, in addition to the water's pressure, helps Francis and other inward-flow turbines harness water energy efficiently.

Problem A turbine develops 7225 kW power under a head of 25 m at 135 rpm. Calculate the specific speed of the turbine and state the type of the turbine.

Solution:

$$P = 7225 \text{ kW}, H = 25 \text{ m}; N = 135 \text{ rpm}$$

$$N_s = \frac{N \sqrt{P}}{H^{5/4}} = \frac{135 \sqrt{7225}}{25^{5/4}} = 205.28$$

Hence it is francis turbine.

Problem: The outer diameter of a Francis runner is 1.4 m. The flow velocity at inlet is 9.5 m/s. The absolute velocity at the exit is 7 m/s. The speed of operation is 430 rpm. The power developed is 12.25 MW, with a flow rate of 12 m³/s. Total head is 115 m. For shockless entry determine the angle of the inlet guide vane. Also find the absolute velocity at entrance, the runner blade angle at inlet and the loss of head in the unit. Assume zero whirl at exit. Also find the specific speed.

$$\text{The runner speed } u_1 = \frac{\pi D N}{60} = \frac{\pi \times 430 \times 14}{60} = 31.52 \text{ m/s}$$

$$\begin{aligned} \text{As } V_{u2} &= 0, \\ \text{Power developed} &= m V_{u1} u_1 \\ 12.25 \times 10^6 &= 12 \times 10^3 \times V_{u1} \times 31.52 \end{aligned}$$

$$\text{Solving } V_{u1} = 32.39 \text{ m/s}$$

$$V_{u1} > u_1$$

∴ The shape of the inlet

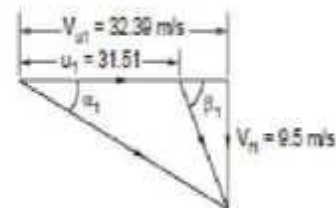

Problem: A Francis turbine developing 16120 kW under an a head of 260 m runs at 600 rpm. The runner outside diameter is 1500 mm and the width is 135 mm. The flow rate is 7 m³/s. The exit velocity at the draft tube outlet is 16 m/s. assuming zero whirl velocity at exit and neglecting blade thickness determine the overall and hydraulic efficiency and rotor blade angle at inlet. Also find the guide vane outlet angle:

$$\text{Overall efficiency} = \frac{\text{Power developed}}{\text{Hydraulic power}} = \frac{16120 \times 10^3}{7 \times 1000 \times 9.81 \times 260}$$

$$\eta_o = 0.9029 \text{ or } 90.29\%$$

$$\text{Hydraulic efficiency} = \left(H - \frac{V_2^2}{2g} \right) / H$$

where V_2 is the exit velocity into the tailrace

$$\eta_H = (260 - (16^2/2 \times 9.81)) / 260$$

$$= 0.9498 \text{ or } 94.98\%$$

As V_{u2} is assumed to be zero,

$$V_{u1} = \eta_H (gH) / u_1$$

$$u_1 = \pi DN / 60 = \frac{\pi \times 15 \times 600}{60} = 47.12 \text{ m/s}$$

$$\therefore V_{u1} = 0.9498 \times 9.81 \times 260 / 47.12 = 51.4 \text{ m/s}$$

$$V_{u1} > u$$

The shape of the velocity triangle is as given. β is the angle taken with the direction of blade velocity.

$$V_f = \frac{Q}{\pi D_1 b_1} = \frac{7}{\pi \times 15 \times 0.135} = 11 \text{ m/s}$$

$$\tan \alpha_1 = 11 / 51.4$$

$$\alpha_1 = 12.08^\circ$$

$$\tan \beta_1 = 11 / (51.4 - 47.12)$$

$$\beta_1 = 68.74^\circ$$

The specific speed of the unit

$$= \frac{600 \sqrt{16120000}}{60 \times 260^{1.25}} = 38.46$$

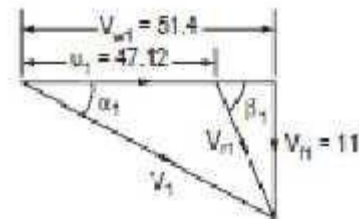

Problem 5.24: A turbine is to operate under a head of 25 m. at 200 rpm. The discharge is 9 cumec. If the overall efficiency is 90%, determine.

1. Power generated
2. Specific speed
3. Type of Turbine.

Solution:

$$H = 25 \text{ m}, N = 200 \text{ rpm}, Q = 9 \text{ cumec}, \eta = 90\%$$

$$1. \quad \eta_0 = \frac{\text{Power developed}}{\text{water power}} = \frac{P}{\frac{\rho g Q H}{1000}} = 0.90$$

$$\therefore P = \frac{0.90 \times \rho \times g \times Q \times H}{1000} = \frac{0.90 \times 1000 \times 9.81 \times 9 \times 25}{1000}$$

$$= 1986.5 \text{ kW}$$

$$2. \quad \text{Sp. Speed } N_s = \frac{N \sqrt{P}}{H^{5/4}} = \frac{200 \sqrt{1986.5}}{25^{5/4}} = 159.46 \text{ rpm}$$

3. Type of Turbine is Francis Turbine.

Specific speed

The specific speed n_s of a turbine dictates the turbine's shape in a way that is not related to its size. This allows a new turbine design to be scaled from an existing design of known performance. The specific speed is also the main criterion for matching a specific hydro -electric site with the correct turbine type.

The formula suggests that the Pelton turbine is most suitable for applications with relatively high hydraulic head, due to the $5/4$ exponent being greater than unity, and given the characteristically low specific speed of the Pelton.

UNIT 5 PUMPS

Centrifugal Pumps

These are so called because energy is imparted to the fluid by centrifugal action of moving blades from the inner radius to the outer radius. The main components of centrifugal pumps are (1) the impeller, (2) the casing and (3) the drive shaft with gland and packing.

Additionally suction pipe with one way valve (foot valve) and delivery pipe with delivery valve completes the system.

The liquid enters the eye of the impeller axially due to the suction created by the impeller motion. The impeller blades guide the fluid and impart momentum to the fluid, which increases the total head (or pressure) of the fluid, causing the fluid to flow out.

The fluid comes out at a high velocity which is not directly usable. The casing can be of simple volute type or a diffuser can be used as desired. The volute is a spiral casing of gradually increasing cross section. A part of the kinetic energy in the fluid is converted to pressure in the casing.

Figure shows a sectional view of the centrifugal pump.

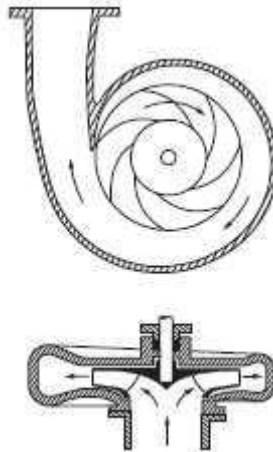

Volute type centrifugal pump.

Gland and packing or so called stuffing box is used to reduce leakage along the drive shaft. By the use of the volute only a small fraction of the kinetic head can be recovered as useful static head.

A diffuser can diffuse the flow more efficiently and recover kinetic head as useful static head. A view of such arrangement is shown in figure Diffuser pump are also called as turbine pumps as these resembles Francis turbine with flow direction reversed.

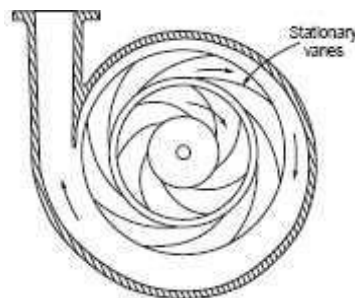

Diffuser pump.

Impeller

The impeller consists of a disc with blades mounted perpendicularly on its surface. The blades may of three different orientations.

These are (i) Radial, (ii) Backward curved, and (iii) Forward curved.

Backward and forward refers to the direction of motion of the disc periphery. Of these the most popular one is the backward curved type, due to its desirable characteristics, which reference to the static head developed and power variation with flow rate.

A simple disc with blades mounted perpendicularly on it is called open impeller. If another disc is used to cover the blades, this type is called shrouded impeller. This is more popular with water pumps. Open impellers are well adopted for use with dirty or water containing solids. The third type is just the blades spreading out from the shaft.

These are used to pump slurries. Impellers may be of cast iron or bronzes or steel or special alloys as required by the application. In order to maintain constant radial velocity, the width of the impeller will be wider at entrance and narrower at the exit. The blades are generally cast integral with the disc. Recently even plastic material is used for the impeller. To start delivery of the fluid the casing and impeller should be filled with the fluid without any air pockets. This is called priming.

If air is present there will be only compression and no delivery of fluid. In order to release any air entrained an air valve is generally provided. The one way foot valve keeps the suction line and the pump casing filled with water.

Classification

As already mentioned, centrifugal pumps may be classified in several ways. On the basis of speed as low speed, medium speed and high speed pumps.

On the basis of direction of flow of fluid, the classification is radial flow, mixed flow and radial flow. On the basis of head pumps may be classified as low head (10 m and below), medium head (10-50 m) and high head pumps.

Single entry type and double entry type is another classification. Double entry pumps have blades on both sides of the impeller disc. This leads to reduction in axial thrust and increase in flow for the same speed and diameter.

When the head required is high and which cannot be developed by a single impeller, multi staging is used. In deep well submersible pumps the diameter is limited by the diameter of the bore well casing. In this case multi stage pump becomes a must. In multi stage pumps several impellers are mounted on the same shaft and the outlet flow of one impeller is led to the inlet of the next impeller and so on. The total head developed equals the sum of heads developed by all the stages.

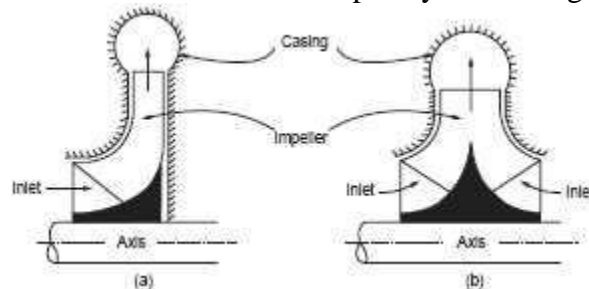

Single and double entry pumps

Pumps may also be operated in parallel to obtain large volumes of flow. The characteristics under series and parallel operations are discussed later in the chapter. The classification may also be based on the specific speed of the pump. In chapter 9 the

dimensionless parameters have been derived in the case of hydraulic machines. The same is also repeated in example.

The expression for the dimensionless specific speed is given in equation

$$N_s = \frac{N\sqrt{Q}}{(gH)^{3/4}}$$

More often dimensional specific speed is used in practice. In this case

$$N_s = \frac{N\sqrt{Q}}{H^{3/4}}$$

Pressure Developed By The Impeller

The general arrangement of a centrifugal pump system is shown in Figure

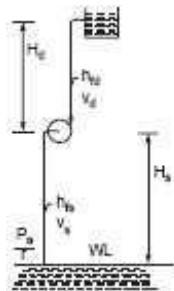

H_s —Suction level above water level.

H_d —Delivery level above the impeller outlet.

h_{fs}, h_{fd} —frictionless m, m .

V_s, V_d —pipe velocities.

Applying Bernoulli's equation between the water level and pump suction,

$$\frac{P_s}{\gamma} + H_s + h_{fs} + \frac{V_s^2}{2g} = \frac{P_d}{\gamma}$$

$$\frac{P_s}{\gamma} + \frac{P_s}{\gamma} H_s + h_{fs} + \frac{V_s^2}{2g}$$

Similarly applying Bernoulli's theorem between the pump delivery and the delivery at the tank

$$\frac{P_d}{\gamma} + \frac{V_d^2}{2g} = \frac{P_a}{\gamma} + H_d + h_{fd} + \frac{V_d^2}{2g}$$

$$\frac{P_d}{\gamma} = \frac{P_a}{\gamma} + H_d + h_{fd}$$

where P_d is the pressure at the pump delivery

$$\frac{P_d}{\gamma} - \frac{P_s}{\gamma} = \frac{P_a}{\gamma} + H_d + h_{fd} - \frac{P_s}{\gamma} + \frac{V_s^2}{2g} + H_s + h_{fs}$$

$$= H_d + H_s + h_{fs} + \frac{V_s^2}{2g} = H_e + \frac{V_s^2}{2g}$$

where H_e is the effective head

Manometric Head

The official code defines the head on the pump as the difference in total energy heads at the suction and delivery flanges. This head is defined as manometric head.

The total energy at suction inlet (expressed as head of fluid)

$$\frac{P_s}{\gamma} + \frac{V_s^2}{2g} + Z_s$$

where Z_s is the height of suction gauge from datum. The total energy at the delivery of the pump

$$= \frac{P_d}{\gamma} + \frac{V_d^2}{2g} + Z_d$$

Z_2 is the height of delivery gauge from datum. The difference in total energy is defined as H_m

$$= \left(\frac{P_d}{\gamma} - \frac{P_s}{\gamma} \right) + \frac{V_d^2 - V_s^2}{2g} + (Z_d - Z_s)$$

$$\frac{P_d}{\gamma} - \frac{P_s}{\gamma} = H_s + \frac{V_s^2}{2g}$$

Substituting $H_m = H_s + \frac{V_s^2}{2g} + (Z_d - Z_s)$

As $(Z_d - Z_s)$ is small and $\frac{V_s^2}{2g}$ is also small as the gauges are fixed as close as possible.

$\therefore H_m = \text{Static head} + \text{all losses.}$

Energy Transfer By Impeller

The energy transfer is given by Euler Turbine equation applied to work absorbing machines,

$$W = -(u_1 V_{u1} - u_2 V_{u2}) = (u_2 V_{u2} - u_1 V_{u1})$$

This can be expressed as ideal head imparted as

$$H_{ideal} = \frac{u_2 V_{u2} - u_1 V_{u1}}{g}$$

The velocity diagrams at inlet and outlet of a backward curved vaned impeller is shown in figure. The inlet whirl is generally zero. There are no guide vanes at inlet to impart whirl. So the inlet triangle is right angled.

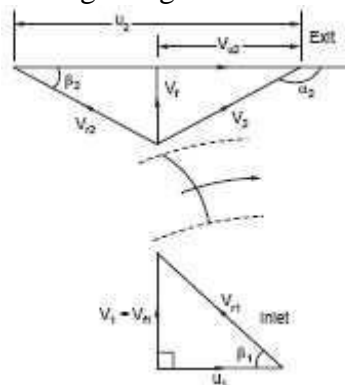

Velocity triangles for backward curved bladed pump.

$V_1 = V_{r1}$ and are radial

$$\tan \beta_1 = \frac{V_1}{u_1} \quad \text{or} \quad \frac{V_r}{u_1}$$

$$V_{u1} = 0$$

$$\therefore H_{ideal} = \frac{u_2 V_{u2}}{g}$$

From the outlet triangle,

$$u_2 = \pi D_2 N/60,$$

$$V_{u2} = u_2 - \frac{V_{r2}}{\tan \beta_2}$$

$$\therefore H_{ideal} = \frac{u_2}{g} \left[u_2 - \frac{V_{r2}}{\tan \beta_2} \right]$$

Manometric efficiency is defined as the ratio of manometric head and ideal head.

$$\eta_m = \frac{H_m \times g}{u_2(u_2 - V_{f2}/\tan \beta_2)}$$

$$H_m = \text{Static head} + \text{all losses (for practical purposes)}$$

$$\text{Mechanical efficiency} = \eta_{\text{mech}} = \frac{\text{Energy transferred to the fluid}}{\text{Work input}}$$

$$= \frac{(u_2 V_{u2}) Q \rho}{\text{power input}}$$

$$\text{Overall efficiency} = \eta_o = \frac{\text{Static head} \times Q \times \rho \times g}{\text{Power input}}$$

There are always some leakages of fluid after being imparted energy by the impeller.

$$\text{Volumetric efficiency} = \frac{\text{Volume delivered}}{\text{Volume passing through impeller}}$$

$$\text{Thus } \eta_o = \eta_m \cdot \eta_{\text{mech}} \cdot \eta_{\text{vol}} \quad (15.3.6)$$

$\frac{V_d^2}{2g}$ is not really useful as output of the pump. Hence the useful amount of energy transfer (as head, is taken as (H_a))

$$H_a = \frac{u_2 V_{u2}}{g} - \frac{V_d^2}{2g}$$

By algebraic manipulation, this can be obtained as

$$H_a = (u_2^2 - V_f^2 \operatorname{cosec}^2 \beta_2) / 2g$$

Slip and Slip Factor

In the analysis it is assumed that all the fluid between two blade passages have the same velocity (both magnitude of direction). Actually at the leading edge the pressure is higher and velocity is lower. On the trailing edge the pressure is lower and the velocity is higher. This leads to a circulation over the blades. Causing a non uniform velocity distribution.

The average angle at which the fluid leaves the blade is less than the blades angle. The result is a reduction in the exit whirl velocity V_{u2} . This is illustrated in the following figure. The solid lines represent the velocity diagram without slip. The angle β_2 is the blade angle. The dotted lines represent the velocity diagram after slip. The angle $\beta_2' < \beta_2$. It may be seen that $V_{u2}' < V_{u2}$. The ratio V_{u2}'/V_{u2} is known as slip factor. The result of the slip is that the energy transfer to the fluid is less than the theoretical value.

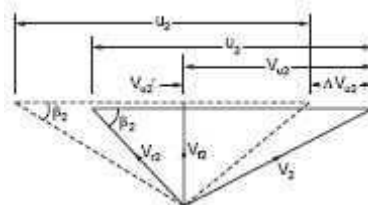

Velocity triangle with slip

$$H_{\text{th}} = \sigma_s \cdot \frac{u_2 V_{u2}}{g}$$

where σ_s is the slip coefficient or slip factor.

Losses in Centrifugal Pumps

Mainly there are three specific losses which can be separately calculated. These are

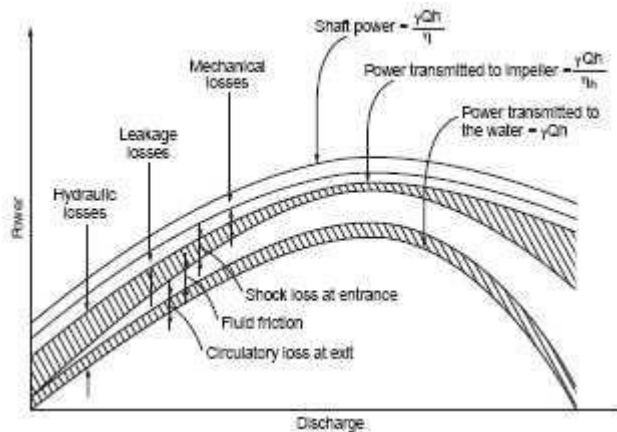

Losses in pump

- (i) Mechanical friction losses between the fixed and rotating parts in the bearings and gland and packing.
- (ii) Disc friction loss between the impeller surfaces and the fluid.
- (iii) Leakage and recirculation losses. The recirculation is along the clearance between the impeller and the casing due to the pressure difference between the hub and tip of the impeller. The various losses are indicated in figure.

Pump Characteristics

We have seen that the theoretical head

$$H_{th} = \frac{u_2 V_{u2}}{g} \quad \text{and} \quad V_{u2} = V_{r2} \cot \beta_2$$

$$V_{r2} = \frac{Q}{A}, \quad \text{where } A \text{ is the circumferential area.}$$

$$u_2 = \pi DN$$

Substituting these relations in the general equation. We can write

$$H_{th} = \pi^2 D^2 N^2 - \left(\frac{\pi DN}{A} \cot \beta_2 \right) Q$$

For a given pump, D , A , β_2 and N are fixed. So at constant speed we can write

$$H_{th} = k_1 - k_2 Q$$

where k_1 and k_2 are constants and

$$k_1 = \pi^2 D^2 N^2 \quad \text{and} \quad k_2 = \left(\frac{\pi DN}{A} \cot \beta_2 \right)$$

For a given pump, D , A , β_2 and N are fixed. So at constant speed we can write

$$H_{th} = k_1 - k_2 Q$$

where k_1 and k_2 are constants and

$$k_1 = \pi^2 D^2 N^2 \quad \text{and} \quad k_2 = \left(\frac{\pi DN}{A} \cot \beta_2 \right)$$

Hence at constant speed this leads to a drooping linear characteristics for backward curved blading. This is shown by curve 1 in Figure 15.4.1. The slip causes drop in the head, which can be written as $\sigma \frac{Vu_2}{u_2/g}$. As flow increases this loss also increases.

Curve 2 shown the head after slip. The flow will enter without shock only at the design flow rate. At other flow rates, the water will enter with shock causing losses.

This loss can be expressed as $h_{shock} = k_3 (Q_{th} - Q)^2$

The reduced head after shock losses is shown in curve 5. The shock losses with flow rate is shown by curve 3. The mechanical losses can be represented by $h_f = k_4 Q^2$. The variation is shown by curve 4. With variation of speed the head characteristic is shifted near parallel with the curve 5 shown in Figure.

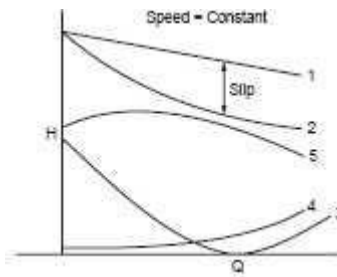

Characteristics of a centrifugal pump

The characteristic of a centrifugal pump at constant speed is shown in Figure. It may be noted that the power increases and decreases after the rated capacity. In this way the pump is self limiting in power and the choice of the motor is made easy. The distance between the brake power and water power curves gives the losses.

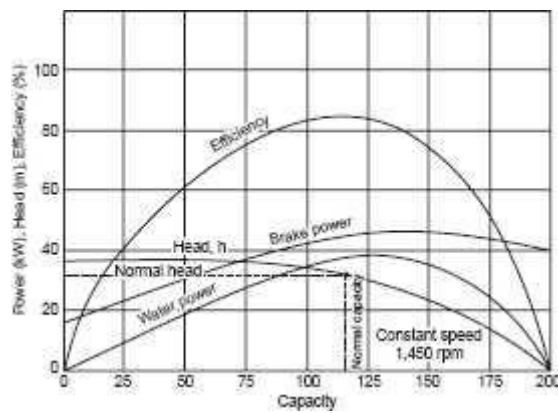

Centrifugal pump characteristics at constant speed

The pump characteristics at various speeds including efficiency contours in shown in Figure. Such a plot helps in the development of a pump, particularly in specifying the head and flow rates.

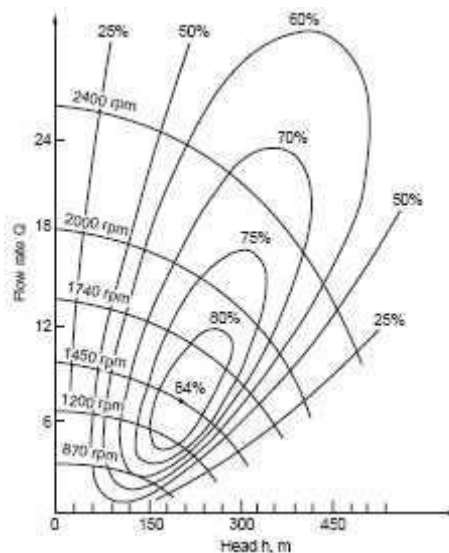

Characteristics at various speeds

Operation of Pumps in Series and Parallel

Pumps are chosen for particular requirement. The requirements are not constant as per example the pressure required for flow through a piping system. As flow increases, the pressure required increases. In the case of the pump as flow increases, the head decreases. The operating condition will be the meeting point of the two curves representing the variation of head required by the system and the variation of head of the pump. This is shown in Figure.

The operating condition decides about the capacity of the pump or selection of the pump. If in a certain setup, there is a need for increased load; either a completely new pump may be chosen. This may be costlier as well as complete revamping of the setup. An additional pump can be the alternate choice. If the head requirement increases the old pump and the new pump can operate in series.

In case more flow is required the old pump and the new pump will operate in parallel. There are also additional advantages in two pump operation. When the Pump-load characteristics load is low one of the pump can operate with a higher efficiency when the load increases then the second pump can be switched on thus improving part load efficiency. The characteristics of parallel operation is depicted in Figure

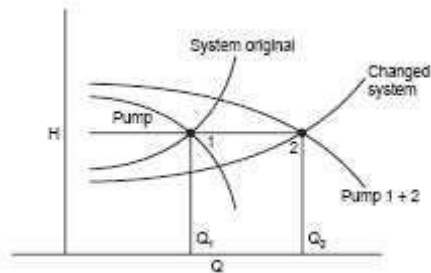

Pumps in parallel

The original requirement was Q_1 at H_1 . Pump 1 could satisfy the same and operating point is at when the flow requirement and the system characteristic is changed such that Q_2 is required at head H_1 , then two pumps of similar characteristics can satisfy the requirement.

Providing a flow volume of Q_2 as head H_1 . It is not necessary that similar pumps should be used. Suitable control system for switching on the second pump should be used in such a case. When the head requirement is changed with flow volume being the same, then the pumps should work in series. The characteristics are shown in Figure.

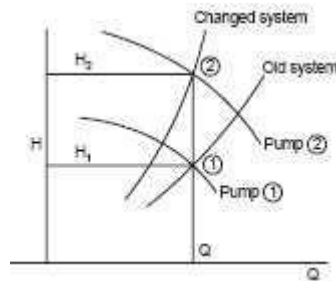

Pumps in series

The flow requirement is Q . Originally head requirement was H_1 met by the first pump alone. The new requirement is flow rate Q and head H_2 . This can be met by adding in series the pump 2, which meets this requirement. It is also possible to meet changes in both

head and flow requirements by the use of two pumps. Suitable control system should be installed for such purposes.

Problem 1: The following details refer to a centrifugal pump. Outer diameter : 30 cm. Eye diameter : 15 cm. Blade angle at inlet : 30° . Blade angle at outlet : 25° . Speed 1450 rpm. The flow velocity remains constant. The whirl at inlet is zero. Determine the work done per kg. If the manometric efficiency is 82%, determine the working head. If width at outlet is 2cm, determine the power $\eta = 76\%$.

$$u_1 = \frac{\pi \times 0.3 \times 1450}{60} = 22.78 \text{ m/s}$$

$$u_2 = 11.39 \text{ m/s}$$

From inlet velocity diagram,

$$V_{r1} = u_1 \tan \beta_1$$

$$= 11.39 \times \tan 30 = 6.58 \text{ m/s}$$

From the outlet velocity diagram,

$$V_{u2} = u_2 - \frac{V_{r2}}{\tan \beta_2} = 22.78 - \frac{6.58}{\tan 25} = 8.69 \text{ m/s}$$

Work done per kg $= u_2 V_{u2} = 22.78 \times 8.69$
 $= 197.7 \text{ Nm/kg/s}$

$$\eta_{mc} = 0.82 = \frac{gH}{197.7}$$

$$\therefore H = 16.52 \text{ m}$$

Flow rate $= \pi \times 0.3 \times 0.02 \times 6.58 = 0.124 \text{ m}^3/\text{s}$

$$\text{Power} = \frac{0.124 \times 10^3 \times 9.81 \times 16.52}{0.76 \times 10^3} = 26.45 \text{ kW.}$$

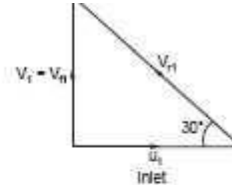

Figure P. 15.1(a)

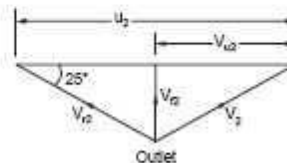

Figure P. 15.1(b)

Minimum Speed For Starting The Centrifugal Pump

$$N = (120 \eta_{man} V_{w2} D) / (\pi(D_2^2 - D^2))$$

Where η_{man} – manometric efficiency
 V - Whirl at out let of the turbine
 D_2 - diameter of impeller at out let

Net Positive Suction Head (NPSH)

The pump manufacturer's specified margin of suction pressure above the boiling point of the liquid being pumped, is required to prevent cavitation. This pressure is called the 'Net Positive Suction Head' pressure (NPSH).

In order to ensure that a NPSH pressure is maintained, the Available NPSH should be higher than that required. The NPSH depends on the height and density of the liquid and the pressure above it.

Cavitation

Cavitations is a problem condition which may develop while a centrifugal pump is operating. This occurs when a liquid boils inside the pump due to insufficient suction head pressure. Low suction head causes a pressure below that of vaporization of the liquid, at the eye of the impeller. The resultant gas which forms causes the formation and collapse of 'bubbles' within the liquid. This, because gases cannot be pumped together with the liquid, causes violent fluctuations of pressure within the pump casing and is seen on the discharge gauge.

These sudden changes in pressure cause vibrations which can result in serious

damage to the pump and, of course, cause pumping inefficiency.

To overcome cavitations:

- (i) Increase suction pressure if possible.
- (ii) Decrease liquid temperature if possible.
- (iii) Throttle back on the discharge valve to decrease flow-rate.
- (iv) Vent gases off the pump casing.

Multistage Pump

If centrifugal pump consists of two or more impellers the pump is called Multistage pump. To produce a high head impellers are connected in series. To produce high discharge impellers are connected in parallel.

Reciprocating Pumps

Introduction

There are two main types of pumps namely the dynamic and positive displacement pumps. Dynamic pumps consist of centrifugal, axial and mixed flow pumps. In these cases pressure is developed by the dynamic action of the impeller on the fluid. Momentum is imparted to the fluid by dynamic action. This type was discussed in the previous chapter. Positive displacement pumps consist of reciprocating and rotary types. These types of pumps are discussed in this chapter. In these types a certain volume of fluid is taken in an enclosed volume and then it is forced out against pressure to the required application.

Comparison

Dynamic pumps

- (i) Simple in construction.
- (ii) Can operate at high speed and hence compact.
- (iii) Suitable for large volumes of discharge at moderate pressures in a single stage.
- (iv) Lower maintenance requirements.
- (v) Delivery is smooth and continuous.

Positive displacement pumps

1. More complex, consists of several moving parts.
2. Speed is limited by the higher inertia of the moving parts and the fluid.
3. Suitable for fairly low volumes of flow at high pressures.
4. Higher maintenance cost.
5. Fluctuating flow.

Description And Working

The main components are:

- (i) Cylinder with suitable valves at inlet and delivery.
- (ii) Plunger or piston with piston rings.
- (iii) Connecting rod and crank mechanism.
- (iv) Suction pipe with one way valve.
- (v) Delivery pipe.
- (vi) Supporting frame.

(vii) Air vessels to reduce flow fluctuation and reduction of acceleration head and friction head.

A diagrammatic sketch is shown in Fig

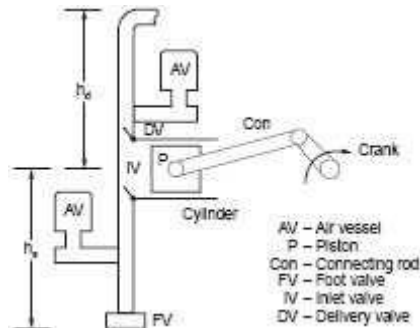

Diagrammatic view of single acting reciprocating pump

The action is similar to that of reciprocating engines. As the crank moves outwards, the piston moves out creating suction in the cylinder. Due to the suction water/fluid is drawn into the cylinder through the inlet valve. The delivery valve will be closed during this outward stroke.

During the return stroke as the fluid is incompressible pressure will developed immediately which opens the delivery valve and closes the inlet valve. During the return stroke fluid will be pushed out of the cylinder against the delivery side pressure. The functions of the air vessels will be discussed in a later section. The volume delivered per stroke will be the product of the piston area and the stroke length.

In a single acting type of pump there will be only one delivery stroke per revolution. Suction takes place during half revolution and delivery takes place during the other half. As the piston speed is not uniform (crank speed is uniform) the discharge will vary with the position of the crank. The discharge variation is shown in figure.

In a single acting pump the flow will be fluctuating because of this operation.

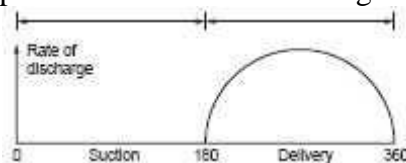

Flow variation during crank movement of single acting pump

Fluctuation can be reduced to some extent by double acting pump or multicylinder pump. The diagrammatic sketch of a double acting pump is shown in figure. In this case the piston cannot be connected directly with the connecting rod.

A gland and packing and piston rod and cross-head and guide are additional components. There will be nearly double the discharge per revolution as compared to single acting pump. When one side of the piston is under suction the other side will be delivering the fluid under pressure. As can be noted, the construction is more complex.

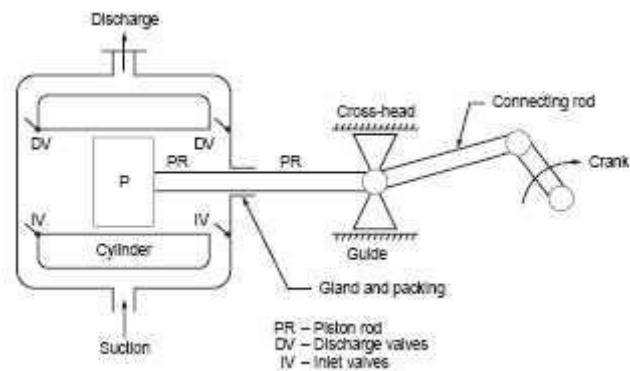

Diagrammatic view of a double action pump

Flow Rate and Power

Theoretical flow rate per second for single acting pump is given by,

$$Q_{SA} = \frac{L A N}{60} \text{ m}^3/\text{s} \quad (16.3.1)$$

Where L is the length of stroke, A is the cylinder or piston area and N is the revolution per minute. It is desirable to express the same in terms of crank radius and the angular velocity as simple harmonic motion is assumed.

$$\omega = \frac{2\pi N}{60}, N = \frac{60 \omega}{2\pi}, r = \frac{L}{2}$$

$$Q_{SA} = \frac{2r \cdot A \times 60 \omega}{2\pi \times 60} = \frac{A \omega r}{\pi} \text{ m}^3/\text{s} \quad (16.3.1a)$$

In double acting pumps, the flow will be nearly twice this value. If the piston rod area is taken into account, then

$$Q_{DA} = \frac{A L N}{60} + (A - A_{pr}) \frac{L N}{60} \text{ m}^3/\text{s} \quad (16.3.2)$$

Compared to the piston area, the piston rod area is very small and neglecting this will lead to an error less than 1%.

$$Q_{DA} = \frac{2A L N}{60} = \frac{2A \omega r}{\pi} \text{ m}^3/\text{s}$$

Slip

There can be leakage along the valves, piston rings, gland and packing which will reduce the discharge to some extent. This is accounted for by the term slip.

$$\text{Percentage of slip} = \frac{Q_{th} - Q_{ac}}{Q_{th}} \times 100$$

Where Q_{th} is the theoretical discharge given by equation and Q_{ac} is the measured discharge.

If actual discharge is greater than theoretical discharge negative value is found this negative value is called negative slip.

Coefficient of discharge

$$\text{Coefficient of discharge, } C_d = \frac{Q_{ac}}{Q_{th}}$$

It has been found in some cases that $Q_{ac} > Q_{th}$, due to operating conditions. In this case the slip is called negative slip. When the delivery pipe is short or the delivery head is small and the accelerating head in the suction side is high, the delivery valve is found to open

before the end of suction stroke and the water passes directly into the delivery pipe. Such a situation leads to negative slip.

$$\text{Theoretical power} = mg(h_s + h_d) W$$

where m is given by $Q \times \delta$.

Problem.1 A single acting reciprocating pump has a bore of 200 mm and a stroke of 350 mm and runs at 45 rpm. The suction head is 8 m and the delivery head is 20 m. Determine the theoretical discharge of water and power required. If slip is 10%, what is the actual flow rate ?

$$\begin{aligned} \text{Theoretical flow volume } Q &= \frac{L A N}{60} = \frac{0.35 \times \pi \times 0.2^2 \times 45}{4 \times 60} \\ &= 8.247 \times 10^{-4} \text{ m}^3/\text{s} \text{ or } 8.247 \text{ l/s} \text{ or } 8.247 \text{ kg/s} \\ \text{Theoretical power} &= (\text{mass flow/s}) \times \text{head in m} \times g \text{ Nm/s or W} \\ &= 0.9 \times 8.247 \times (20 + 8) \times 9.81 \\ &= 3039 \text{ W or } 3.039 \text{ kW} \\ \text{Slip} &= \frac{Q_{th} - Q_{act}}{Q_{th}}, 0.1 = \frac{8.247 - Q_{act}}{8.247} \\ \therefore Q_{actual} &= 7.423 \text{ l/s} \\ \text{The actual power will be higher than this value due to both solid and fluid friction.} \end{aligned}$$

Indicator Diagram

The pressure variation in the cylinder during a cycle consisting of one revolution of the crank. When represented in a diagram is termed as indicator diagram. The same is shown in figure.

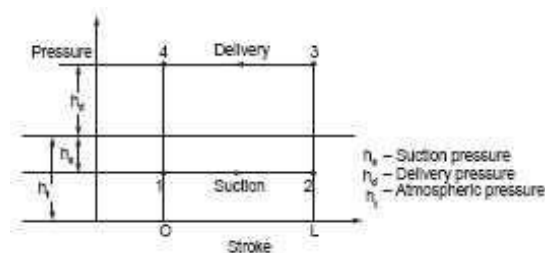

Indicator diagram for a crank revolution

Figure represents an ideal diagram, assuming no other effects are involved except the suction and delivery pressures. Modifications due to other effects will be discussed later in the section. Point 1 represents the condition as the piston has just started moving during the suction stroke.

1-2 represents the suction stroke and the pressure in the cylinder is the suction pressure below the atmospheric pressure. The point 3 represents the condition just as the piston has started moving when the pressure increases to the delivery pressure. Along 3-4 representing the delivery stroke the pressure remains constant. The area enclosed represents the work done during a crank revolution to some scale.

$$\text{Power} = Q \rho g (h_s + h_d) = \rho g L A N (h_s + h_d) / 60$$

Acceleration Head

The piston in the reciprocating pump has to move from rest when it starts the suction stroke. Hence it has to accelerate. The water in the suction pipe which is also not flowing at this point has to be accelerated. Such acceleration results in a force which when divided by area results as pressure.

When the piston passes the mid point, the velocity gets reduced and so there is retardation of the piston together with the water in the cylinder and the pipe. This again results

in a pressure. These pressures are called acceleration pressure and is denoted as head of fluid ($h = P/\rho g$) for convenience.

Referring to the figure shown below the following equations are written.

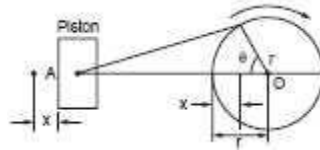

Piston Crank Configuration

Let ω be the angular velocity.

Then at time t , the angle travelled $\theta = \omega t$

Distance $x = r - r \cos \theta = r - r \cos \omega t$

Velocity at this point,

$$v = \frac{dx}{dt} = \omega r \sin \omega t$$

The acceleration at this condition

$$\dot{x} = \frac{dv}{dt} = \omega^2 r \cos \omega t$$

This is the acceleration in the cylinder of area A . The acceleration in the pipe of area a is $= A/a \omega^2 r \cos \omega t$. This head is imposed on the piston in addition to the static head at that condition. This results in the modification of the indicator diagram as shown in figure.

Accelerating force = mass \times acceleration

$$\text{mass in the pipe} = \rho a l \text{ kg} = \frac{\gamma a l}{g}$$

$$\therefore \text{Acceleration force} = \frac{\gamma a l}{g} \times \frac{A}{a} \omega^2 r \cos \omega t$$

Pressure = force/area

$$= \frac{\gamma a l}{g} \cdot \frac{1}{a} \cdot \frac{A}{a} \omega^2 r \cos \omega t$$

$$= \frac{\gamma l}{g} \cdot \frac{A}{a} \omega^2 r \cos \theta$$

Head = Pressure/ γ

$$h_a = \frac{l}{g} \cdot \frac{A}{a} \omega^2 r \cos \theta$$

This head is imposed on the piston in addition to the static head at that condition. This results in the modification of the indicator diagram as shown in figure.

This head is imposed on the piston in addition to the static head at that condition. This results in the modification of the indicator diagram as shown in figure 16.4.3.

(i) Beginning of suction stroke: $\theta = 0$, $\cos \theta = 1$

$$\therefore h_{as} = \frac{l_s}{g} \cdot \frac{A}{a_s} \cdot \omega^2 r$$

This is over and above the static suction head. Hence the pressure is indicated by 1' in the diagram.

(ii) Middle of stroke: $\theta = 90^\circ \therefore h_{as} = 0$. There is no additional acceleration head.

(iii) End of stroke: $\theta = 180^\circ$, $\cos \theta = -1$

$$\therefore h_{as} = -\frac{l_s}{g} \cdot \frac{A}{a_s} \cdot \omega^2 r$$

This reduces the suction head. Hence the pressure is indicated at 2' in the diagram.

Similarly during the beginning of the delivery stroke

$$\theta = 0, \cos \theta = 1$$

$$h_{ad} = \frac{l_d}{g} \cdot \frac{A}{a_d} \cdot \omega^2 r$$

This head is over and above the static delivery pressure. The pressure is indicated by

point 3' in the diagram. At the middle stroke $h_{ad} = 0$. At the end of the stroke $h_{ad} = -\frac{l_d}{g} \cdot \frac{A}{a_d} \cdot \omega^2 r$.

This reduces the pressure at this condition and the same is indicated by 4' in the diagram.

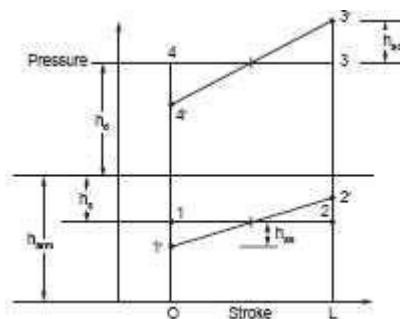

Modified indicator diagram due to acceleration head

The effect of acceleration head are:

No change in the work done. pressure at 1' is around 2.5 m of head of water (absolute). Which is directly related to speed, the speed of operation of reciprocating pumps is limited. Later it will be shown that the installation of an air vessel alleviates this problem to some extent.

Work done by the Pump

For single acting

$$W = \rho g A L N (h_s + h_d + 0.67 h_{fs} + 0.67 h_{fd}) / 60$$

For Double acting

$$W = 2 \rho g A L N (h_s + h_d + 0.67 h_{fs} + 0.67 h_{fd}) / 60$$

Where h_{fs} , h_{fd} = loss of head due to acceleration in the suction and delivery Pipe.

Air Vessels

Air vessel is a strong closed vessel as shown in figure. The top half contains compressed air and the lower portion contains water or the fluid being pumped. Air and water are separated by a flexible diaphragm which can move up or down depending on the difference in pressure between the fluids. The air charged at near total delivery pressure/suction pressure from the top and sealed. The air vessel is connected to the pipe lines very near the pump, at nearly the pump level. On the delivery side, when at the beginning and up to the middle of the delivery stroke the head equals $h_s + h_f + h_a$, higher than the static and friction heads. At this time part of the water from pump will flow into the air vessel and the remaining will flow through the delivery pipe. This will increase the compressed air pressure. At the middle stroke position the head will be sufficient to just cause flow. The whole of the flow from pump will flow to the delivery pipe. At the second half of the stroke the head will be equal to $h_s + h_f - h_a$. At the position the head will be not sufficient to cause flow. The compressed air pressure will act on the water and water charged earlier into the air vessel will now flow out. Similar situation prevails on the suction side. At the start and up to the middle of the suction stroke the head at the pump is higher than static suction head by the amount of acceleration head. The flow will be more and part will flow into the air vessel. The second half of the stroke water will flow out of the air vessel.

In this process the velocity of water in the delivery pipe beyond the air vessel is uniform, and lower than the maximum velocity if air vessel is not fitted. Similar situation prevails in the suction side also. The effect is not only to give uniform flow but reduce the friction head to a considerable extent saving work. Without air vessel the friction head increases, reaches a maximum value at the mid stroke and then decreases to zero. With air vessel the friction head is lower and is constant throughout the stroke. This is due to the constant velocity in the pipe.

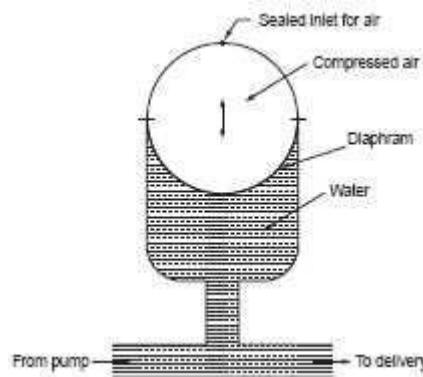

The advantages of installing air vessels are:

- (i) The flow fluctuation is reduced and a uniform flow is obtained.
- (ii) The friction work is reduced.
- (iii) The acceleration head is reduced considerably.
- (iv) Enables the use of higher speeds.

Types of positive displacement pump

- Rotary pumps
- Reciprocating (piston) pumps
- Gear pump

Rotary Pumps

In Rotary pumps, movement of liquid is achieved by mechanical displacement of liquid produced by rotation of a sealed arrangement of intermeshing rotating parts within the pump casing.

The gear pump Construction and Operation:

In this pump, intermeshing gears or rotors rotate in opposite directions, just like the gears in a vehicle or a watch mechanism. The pump rotors are housed in the casing or stator with a very small clearance between them and the casing. (The fluid being pumped will lubricate this small clearance and help prevent friction and therefore wear of the rotors and casing).

In this type of pump, only one of the rotors is driven. The intermeshing gears rotate the other rotor. As the rotors rotate, the liquid or gas, (this type of machine can also be used as a compressor), enters from the suction line and fills the spaces between the teeth of the gears and becomes trapped forming small 'Slugs' of fluid between the teeth.

The slugs are then carried round by the rotation of the teeth to the discharge side of the pump.

At this point, the gears mesh together and, as they do so, the fluid is displaced from each cavity by the intermeshing teeth.

Since the fluid cannot pass the points of near contact of the intermeshed teeth nor between the teeth and casing, it can only pass into the discharge line.

As the rotation continues, the teeth at the suction end are opened up again and the same amount of fluid will fill the spaces and the process repeated. The liquid at the discharge end is constantly being displaced (moved forward).

Thus gear pumps compel or force a fixed volume of fluid to be displaced for each revolution of the rotors giving the 'Positive Displacement' action of the pump.

Gear pumps are generally operated at high speed and thus give a fairly pulse-free discharge flow and pressure. Where these pumps are operated at slower speeds, as in pumping viscous liquids, the output tends to pulsate due to the meshing of the teeth. Any gas or air drawn into the pump with the liquid, will be carried through with the liquid and will not cause cavitation. This action of the pump means that it's a 'Self Priming' pump. The discharge pressure may however, fluctuate.

The output from this type of pump is directly proportional to the speed of operation. If the speed is doubled, the output will be doubled and the pressure will have very little effect. (At higher pressures, due to the fine clearances between the teeth and between the casing and the rotors, a small leakage back to the suction side will occur resulting in a very small drop in actual flow rate. The higher the discharge pressure, the more likely that internal leakage will occur).

Rotary pumps are widely used for viscous liquids and are self-lubricating by the fluid being pumped. This means that an external source of lubrication cannot be used as it would contaminate the fluid being pumped. However, if a rotary pump is used for dirty liquids or slurries, solid particles can get between the small clearances and cause wear of the teeth and casing. This will result in loss of efficiency and expensive repair or replacement of the pump.

TWO MARKS QUESTION AND ANSWERS

1. What do you mean by turbine?

The hydraulic machine which convert the hydraulic energy in to mechanical energy is called turbine

2. Define pump :

It is defined as the hydraulic machine which convert mechanical energy in to hydraulic energy

3. Define sub critical flow:

If the froude number is less than one then the flow is said to be sub critical flow

4. Define critical flow:

If the froude number is less equal to one it is called as critical flow.

5. Define supercritical flow:

If the froude number is greater than one it is called as super critical flow

6. What are the possible types of flow in open channel with respect to space and time?

A, steady and unsteady flow

B, uniform and nonuniform flow

7. what do you know about uniform and non uniform flow?

Uniform flow: If the given length of the channel ,depth ,velocity ,the rate of flow, cross section are constant.

Non Uniform flow: If the given length of the channel ,depth ,velocity ,the rate of flow, cross section are not constant.

8. Define specific energy:

It is defined as energy per unit weight of the liquid with respect to the bottom of the channel.

9. What is meant by wetted perimeter?

The wetted perimeter (p) is the length of the line of intersection of the channel wetted surface with the cross section plan normal to the direction of flow.

10. Define critical depth:

It is defined as the depth of flow of water at which the specific energy is minimum.

11. Define critical velocity:

The velocity of flow at the critical depth is known as critical velocity.

12. Define the term most economical section of the channel:

A section of the channel is said to be most economical when the cost of construction of the channel is minimum. But the cost of construction depend up on the excavation and lining to keep the cost minimum The wetted perimeter for a given discharge should be minimum.

13. Define gradually varying flow

If the change in depth in a varying flow is gradual so that the curvature of the streaming line is not excessive such flow is called gradually varying flow.

14. Define Rapidly varying flow

If the curvature in a varied flow is large and depth changes appreciably over short length it is called rapidly varying flow.

15. Define afflux

The maximum increase in water level due to obstruction in the path of flow is known as afflux.

15. Define length of backwater curve

The distance along the bed of the channel between the section where water starts raising to the section where water is having maximum height is known as the length of the back water curve

16. Define back water

The profile of the raising water on the upstream side of the dam is called as back water curve.

17. Define hydraulic jump

The raise of water level which takes place due to the transformation of the unstable shooting flow (super critical flow) to the stable Streaming flow (sub critical flow) is called hydraulic jump.

18. Define cavitations

cavitations is defined as phenomenon of formation of vapour bubbles in a region of a flowing liquid where the pressure in the liquid is falls below than vapour pressure and sudden collapsing of these vapour bubbles in a region of higher pressure.

19. What is known by governing of a turbine?

Governing of a turbine is defined as the operation by which the speed of the turbine is kept constant under all conditions of working . It is done by oilpressure generator.

20. Explain gross head

The difference between head race level and tail race level when no water is flowing is

known as gross head

21. Explain net head

It is defined as the head available at the inlet of turbine. If H_f is the loss due to friction between water and penstock then net head

$$H = H_g - H_f$$

22. Define Hydraulic Efficiency:

It is defined as the ratio of power delivered to the runner to the power supplied at the inlet.

23. Define mechanical efficiency

It is defined as the ratio of power at the shaft of the turbine to the power delivered by the water to runner.

24. Define volumetric efficiency

It is defined as the ratio of volume of water actually striking the runner to the Volume of water supplied to the runner.

25. Define over all efficiency

It is defined as the ratio of shaft power by water power

26. Explain impulse turbine

If at the inlet of the turbine the energy available is only kinetic energy the turbine is known as impulse turbine.

27. Explain Reaction turbine

if at the inlet of the turbine the water possesses kinetic energy as well as pressure energy the turbine is known as reaction turbine.

28. Explain tangential flow turbine

If the water flows along the tangent of the runner, the turbine is known as the tangential flow turbine.

29. Explain radial flow turbine

If the water flows in the radial direction through the runner the turbine is called radial flow turbine.

30. Explain inward flow radial turbine

If the water flows from outwards to inwards radially the turbine is called inward radial

flow turbine.

31. Explain outward flow radial turbine

If the water flows radially from inwards to outwards the turbine is known as outward radial flow turbine.

32. Define axial flow turbine

If the water flows through the runner along the direction parallel to the axis of rotation of the runner the turbine is called axial flow turbine.

33. What is Pelton wheel:

Pelton wheel or Pelton turbine is a tangential flow impulse turbine. The water strikes the bucket along the tangent of the runner. The energy available at the inlet of the Turbine is only kinetic energy. This turbine is used for high heads.

34. What is braking jet?

When the nozzle is completely closed, the amount of water striking the runner reduces to zero but the runner due to inertia goes on revolving for a long time to stop the runner in a short time a small nozzle is provided which directs the jet of water on the back of vanes. This jet of water is called braking jet.

35. What is jet ratio?

It is the ratio of pitch diameter (D) to the diameter of jet (d).

36. What is Draft tube?

A tube or pipe of gradually increasing area is used for discharging water from the exit of the turbine to the tail race is called draft tube.

37. Define Degree of Reaction (R)

It is defined as the ratio of change of pressure energy inside the runner to the change of total energy outside the runner.

38. What is radial discharge?

This means the angle made by absolute velocity with the tangent on the wheel is 90° and the component of whirl velocity is zero.

39. Define Francis turbine:

Inward flow reaction turbine having radial discharge at outlet is known as Francis turbine

40. Define propeller turbine:

This is an example of axial flow reaction turbine . Here the vanes are fixed to the hub and are not adjustable.

41. Define Kaplan turbine:

This is an example of axial flow reaction turbine. Here the vanes are not fixed to the hub and are adjustable.

42. What are the use of draft tube?

1. the net head on the turbine increases.
2. due to increase in net head the power and efficiency of the turbine also increases.
3. the large amount of rejected kinetic energy is converted in to usefull pressure energy

43. What are types of draft tube?

1. conical draft tube
2. simple elbow tube
3. moody spreading tube
3. draft tube with circular inlet and rectangular outlet.

44. What are the types of characteristic curves

1. Main characteristic curves
2. Operating characteristic curve
3. Muschel characteristic curves

45. What is specific speed of the turbine?

It is defined as the speed of a turbine which will develop unit power under unit head.

46. Define unit quantities;

Unit quantities are the quantities which are obtained when the head on the turbine are unity.

47. Explain about characteristic curves of a hydraulic turbine

Characteristic curves of a hydraulic turbine are the curves with the help of which the exact behaviour and performance of the turbine under different working conditions can be known.

48. What is meant by conveyance of the channel?

The conveyance of the channel is denoted by k and is given by $k=AC\sqrt{m}$.

49. Define the term most economical section:

A section of the channel is said to be most economical when the cost of construction of the channel is minimum. But the cost of construction mainly depend up on the excavation and lining to keep the cost minimum ,the wetted perimeter for a given discharge should be minimum.

50. What are the conditions of rectangular channel of best section?

The two conditions are breadth is equal to two times the depth ($b=2d$) and hydraulic mean depth is equal to half the depth ($m=d/2$)

51. Write down the conditions for the most economical trapezoidal channel?

1. Half the top width is equal to one of sloping side $(b+2nd)/2=d\sqrt{(1+n^2)}$
2. Hydraulic mean depth is equal to half the depth.

52. Write down the conditions of most economical circular channel with maximum velocity?

$$\theta=128^{\circ}45'$$

$$d=0.81D$$

$$m=0.3D$$

53. What do you mean by open channel flow?

1. Open channel flow has a free surface which is subjected to atmospheric pressure.
2. In open channel flow the cross section is irregular.

54. What do you mean by pipe flow?

1. Pipe flow has no free surface and subjected to hydraulic pressure only.
2. The cross section of the flow is fixed

55. List the instrument used to measure open channel flow

1. pitot tube
2. ultrasonic flow instrument.
3. Dropper instrument
4. Gurley instrument.

56. What is the best side slope for trapezoidal channel ?

$\theta=60^\circ$ is the best side slope for trapezoidal channel.

57. what do mean by M₁ profile?

The most common of all gradually varying flow is of M₁ type which is a sub critical flow condition obstructions to flow such as wiers, dams etc...which produce M₁ profile.

58. What are the types of flow profile?

Mild slope profile
 Steep slope profile
 Critical slope profile
 Horizontal bed profile
 Adverse slope profile

59. What do you mean by M₂ profile?

The M₂ profile occurs at a sudden drop in the bed of the channel in to the ponds or pools or lakes.

60. What do mean by M₃ profile?

The M₃ profile occurs the flow yielding from a spillway or a sluice gate.

61. What is speed ratio?

$$U_1 = \phi \sqrt{2gH}$$

Where U₁ – tangential velocity of wheel at inlet

ϕ -speed ratio

H – Head of the turbine.

62. What do you mean by coefficient of velocity?

$$V_1 = C_v \sqrt{2gH}$$

V₁ = velocity of jet

C_v = coefficient of velocity

H = head of the turbine.

63. What are the main parts of pelton wheel turbine?

1. nozzle and flow regulating arrangement
2. runner with buckets

3. casing
4. breaking jet

64. What are the main mechanism of Radial flow reaction turbine?

- 1.casing
- 2.guide mechanism
- 3.runner
- 4.draft tube

65. Define Multistage pump:

If centrifugal pump consists of two or more impellers the pump is called multistage pump. To produce a high head impellers are connected in series. To produce high discharge impellers are connected in parallel.

66. Define Manometric head:

Manometric head is the head against which a centrifugal pump has to work.

$$H_m = H_s + h_d + H_{fs} + H_{fd} + (vd^2/2g)$$

Where H_m – manometric head

H_s - suction head

H_d – delivery head

H_{fs} – friction head loss in suction pipe

H_{fd} – friction head loss in delivery pipe

67. What is Net Positive Suction Head (NPSH) ?

NPSH is defined as the total head required to make liquid flow through suction pipe to pipe impeller.

68. Define slip of a reciprocating pump and negative slip:

Slip is defined as the difference between theoretical discharge and actual discharge.

If actual discharge is greater than theoretical discharge negative value is found this negative value is called negative slip.

69. What do you know coefficient of discharge?

It is defined as the ratio of actual discharge by theoretical discharge. It is denoted By C_d .

70. What do you know Drop downcurve?

The water surface has a convex profile upwards this curve is called drop down curve.

71. What is separation of reciprocating pump?

If the pressure in the cylinder is below the vapour pressure, dissolved gases will be liberated from the liquid and cavitations will take place. The continuous flow of liquid will not exit which means separation of liquid takes place. The pressure at which separation takes place is called separation pressure and head corresponding to the separation pressure is called separation pressure head.

72. What is an indicator diagram?

Indicator diagram is the graph between the pressure head and distance traveled by the piston from inner dead center for one complete revolution.

73. What is Air vessel?

Air vessel is a closed chamber containing compressed air in the top portion and liquid at the bottom of the chamber. It is used to obtain a continuous supply of water at uniform rate to save a considerable amount of work and to run the pump at high speed without separation.

74. What are the assumptions of gradually varying flow profile?

1. Pressure distribution at any section is assumed to be hydrostatic.
2. The velocity distribution at the channel section is fixed
3. The channel is prismatic
4. The roughness coefficient is independent of the depth of flow.

75. What are the two cases where distance of the normal depth of flow does not exist?

- (a) When the channel bed is horizontal
- (b) When the channel bed has an adverse slope.

76. What are the methods used for finding gradually varying flow profile?

1. Direct integration method
2. Numerical method
3. Graphical representation method.

77. What are the classifications of hydraulic turbine according to the type of energy at inlet?

- (a) Impulse turbine and
- (b) Reaction turbine

78. What are the types of turbine according to direction of flow through runner?

- (a) Tangential flow turbine
- (b) Radial flow turbine
- (c) Axial flow turbine
- (d) Mixed flow turbine

79. What are the types of turbine according to the head at the inlet of the turbine?

- (a) high head turbine
- (b) medium head turbine
- (c) low head turbine

80. What are the types of turbine according to the specific speed of the turbine?

- (a) Low specific speed turbine
- (b) Medium specific speed turbine
- (c) High specific speed turbine.

81. Write down the expression for energy loss due to hydraulic jump?

$$H_L = (d_2 - d_1)^3 / (4d_1d_2)$$

Where

H_L – energy loss due to hydraulic jump

D_2 - depth of flow after the jump

D_1 -- depth of flow before the jump

82. What do you mean by length of hydraulic jump?

This is defined as the length between the two sections where one section is taken before the hydraulic jump and the second section is taken immediately after the jump.

83. What are the classification of flow in channels?

1. steady flow and un steady flow.
2. uniform flow and non uniform flow.
3. Laminar flow and turbulent flow and
4. sub critical , critical and super critical flow.

84. What are the types of Non uniform flow?

- (i) Rapidly Varied Flow (R.V.F)
- (ii) Gradually Varied Flow (G.V.F)

85. What do you know about laminar and turbulent flow?

Laminar flow: The flow in open channel is said to be laminar if the Reynolds number(Re) is less than 500

Turbulent flow: If the Reynolds number is greater than 2000 it is called turbulent flow.

86. What do you mean by specific energy curve?

It is defined as the curve which shows the variation of specific energy with respect to depth of flow.

87. Write the manometric efficiency of the pump?

$$\text{Manometric efficiency} = (gH_m)/(V_w^2 U_2)$$

Where

H_m –manometric head

88. Write the expression for over all efficiency ? over all efficiency

$$= (\rho g Q H_m)/(1000 \times P) \text{ Where}$$

H_m – manometric head

P - power

89. What is the minimum speed for starting the centrifugal pump?

$$N = (120 \eta_{\text{man}} V_{w2} D) / (\pi(D_2^2 - D_1^2)) \text{ Where}$$

η_{man} – manometric efficiency

V_{w2} – Whirl at out let of the turbine

D_2 – diameter of impeller at out let

90. Write down the use of centrifugal pump?

1. Used in deep sump and basement
2. The high discharge capacity
3. It is driven by electric motors

91. Define open channel flow?

The term *open channel flow* denotes the gravity-driven flow of a liquid with a free surface.

92. What do you mean by streamlining?

Streamlining is adding a faired tail section to reduce the extent of separated flow on the downstream portion of an object.

93. What is centrifugal pump?

The hydraulic machines which convert mechanical energy in to pressure energy by means of centrifugal force is called centrifugal pump. It acts a reverse of inward radial flow turbine.

94. What do you know about Hub or Boss?

It is the core part of the axial flow turbine where the vanes are attached.

95. Under what head the propeller turbine take water?

About 100 m head the propeller turbine take water.

When the vanes are fixed to the hub and they are not adjustable the turbine is called propeller turbine.

96. What are the uses of Kaplan turbine?

1. To produce more out put.
2. The efficiency of the turbine is more

97. Define unit speed:

It is defined as the speed of the turbine under unit head

Where

$$N_u = N/\sqrt{H}$$

N_u –unit speed

N –number of rotations

H - head of the turbine

98. Define unit discharge

It is defined as the discharge passing through the turbine which is working under unit head.

$$Q_u = Q / \sqrt{H}$$

Where

Q_u – unit discharge

Q – Total discharge

H - head of the turbine

99. Define unit power:

It is defined as the power developed by the turbine working under unit head.

$$P_u = P / H^{3/2}$$

Where P_u - unit power.

P - Total power.

H - head of the turbine.

100. What are the main parts of centrifugal pump?

- 1.Suction pipe with foot valve and strainer
2. Impeller
3. casing
- 4.delivery pipe

101. What are fluid machines?

The machines which use the liquid or gas for the transfer of energy from fluid to rotor or from rotor to fluid, are known as fluid machines.

102. What are hydraulic machines and thermal turbo machines?

If liquid is used for the transfer of energy, then machines are known as hydraulic machines whereas if gas is used then machines are known as thermal turbo machines.

103. How are fluid machines classified?

Fluid machines are classified into 2 categories depending upon the direction of transfer of energy :

1. Turbines
2. Pumps or compressors..

104. What is the purpose of an air vessel fitted in the pump?

1. To obtain a continuous supply of liquid at a uniform rate.
2. To save a considerable amount of work in overcoming the frictional resistance in the suction and delivery pipes, and
3. To run the pump at a high speed with out separation.

105. What is the work saved by fitting a air vessel in a single acting ,double acting pump?

Work saved by fitting air vessels in a single acting pump is 84.87%,
In a double acting pump the work saved is 39.2%.

106. What is Discharge through a Reciprocating Pump in Per sec ?

For Single acting

$$\text{Discharge (Q)} = ALN/60$$

Where

A = Area of the Cylinder in m²
 L = Length of Stroke in m. N = Speed
of Crank in RPM

For Double acting

$$Q = 2ALN/60$$

107. What is the Workdone by Reciprocating Pump Per sec.?

$$\text{Workdone} = \rho g ALN(h_s + h_d)/60 \text{ (for single acting)}$$

For Double acting:

$$\text{Work done} = 2\rho g ALN(h_s + h_d)/60$$

Where

ρ = Density of Water in kg/m³
 A = Area of the Cylinder in m²
 L = Length of Stroke in m
 N = Speed in rpm
 h_s, h_d = Suction and Delivery head in m

108. What is the Pressure head due to acceleration in the Suction & Delivery Pipe ?

$$h_f = 4fl(A/a^2 \omega r \sin\theta) / 2gd$$

where

f = Co-efficient of friction. A = Area of piston in m^2 . a = Area of pipe in m^2 .

ω = Angular speed r = Radius of crank

109. What is the relation between Work done of a Pump and Area of Indicator Diagram ?

Work done by the pump is Proportional to the area of the Indicator diagram.

110.. What is the Work done by the Pump per sec due to acceleration and friction in the suction and delivery Pipes ?

For single acting

$$W = \rho g A L N (h_s + h_d + 0.67 h_{fs} + 0.67 h_{fd}) / 60$$

For Double acting

$$W = 2 \rho g A L N (h_s + h_d + 0.67 h_{fs} + 0.67 h_{fd}) / 60$$

Where h_{fs} , h_{fd} = loss of head due to acceleration in the suction and delivery Pipe.

111.. What is the Mean Velocity of Single acting reciprocating pump ?

$$v = A \omega r / 3.14 a$$

Where

ω = Angular velocity in rad/sec r = Radius of the crank in m

A and a = Area of cylinder and Pipe in m^2

mp and rotating cylinder pump.